

Service Manual



TG 2000 Signal Generation Platform

070-9299-01

Warning

The servicing instructions are for use by qualified personnel only. To avoid personal injury, do not perform any servicing unless you are qualified to do so. Refer to all safety summaries prior to performing service.



Copyright © Tektronix, Inc. All rights reserved.

Tektronix products are covered by U.S. and foreign patents, issued and pending. Information in this publication supercedes that in all previously published material. Specifications and price change privileges reserved.

Printed in the U.S.A.

Tektronix, Inc., P.O. Box 1000, Wilsonville, OR 97070-1000

TEKTRONIX and TEK are registered trademarks of Tektronix, Inc.

Windows and Microsoft are registered trademarks of the Microsoft corporation.

WARRANTY

Tektronix warrants that the products that it manufactures and sells will be free from defects in materials and workmanship for a period of one (1) year from the date of shipment. If a product proves defective during this warranty period, Tektronix, at its option, either will repair the defective product without charge for parts and labor, or will provide a replacement in exchange for the defective product.

In order to obtain service under this warranty, Customer must notify Tektronix of the defect before the expiration of the warranty period and make suitable arrangements for the performance of service. Customer shall be responsible for packaging and shipping the defective product to the service center designated by Tektronix, with shipping charges prepaid. Tektronix shall pay for the return of the product to Customer if the shipment is to a location within the country in which the Tektronix service center is located. Customer shall be responsible for paying all shipping charges, duties, taxes, and any other charges for products returned to any other locations.

This warranty shall not apply to any defect, failure or damage caused by improper use or improper or inadequate maintenance and care. Tektronix shall not be obligated to furnish service under this warranty a) to repair damage resulting from attempts by personnel other than Tektronix representatives to install, repair or service the product; b) to repair damage resulting from improper use or connection to incompatible equipment; c) to repair any damage or malfunction caused by the use of non-Tektronix supplies; or d) to service a product that has been modified or integrated with other products when the effect of such modification or integration increases the time or difficulty of servicing the product.

THIS WARRANTY IS GIVEN BY TEKTRONIX IN LIEU OF ANY OTHER WARRANTIES, EXPRESS OR IMPLIED. TEKTRONIX AND ITS VENDORS DISCLAIM ANY IMPLIED WARRANTIES OF MERCHANTABILITY OR FITNESS FOR A PARTICULAR PURPOSE. TEKTRONIX' RESPONSIBILITY TO REPAIR OR REPLACE DEFECTIVE PRODUCTS IS THE SOLE AND EXCLUSIVE REMEDY PROVIDED TO THE CUSTOMER FOR BREACH OF THIS WARRANTY. TEKTRONIX AND ITS VENDORS WILL NOT BE LIABLE FOR ANY INDIRECT, SPECIAL, INCIDENTAL, OR CONSEQUENTIAL DAMAGES IRRESPECTIVE OF WHETHER TEKTRONIX OR THE VENDOR HAS ADVANCE NOTICE OF THE POSSIBILITY OF SUCH DAMAGES.

Service Assurance

If you have not already purchased Service Assurance for this product, you may do so at any time during the product's warranty period. Service Assurance provides Repair Protection and Calibration Services to meet your needs.

Repair Protection extends priority repair services beyond the product's warranty period; you may purchase up to three years of Repair Protection.

Calibration Services provide annual calibration of your product, standards compliance and required audit documentation, recall assurance, and reminder notification of scheduled calibration. Coverage begins upon registration; you may purchase up to five years of Calibration Services.

Service Assurance Advantages

- Priced well below the cost of a single repair or calibration
- Avoid delays for service by eliminating the need for separate purchase authorizations from your company
- Eliminates unexpected service expenses

For Information and Ordering

For more information or to order Service Assurance, contact your Tektronix representative and provide the information below. Service Assurance may not be available in locations outside the United States of America.

Name	VISA or Master Card number and expiration
Company	date or purchase order number
Address	Repair Protection (1,2, or 3 years)
City, State, Postal code	Calibration Services (1,2,3,4, or 5 years)
Country	Instrument model and serial number
Phone	Instrument purchase date

Table of Contents

General Safety Summary	vii
Service Safety Summary	ix
Preface	xi
Specifications	
Specifications	1-1
Product Description	1-1
Accessories	1-2
Characteristics Tables	1-3
Operating Information	
Installation	2-1
Operating Information	2-6
Theory of Operation	
Block Level Description	3-1
Performance Verification	
Verification Interval	4-1
Test Equipment Required	4-1
Preparation	4-2
Verification Procedures	4-2
Adjustment Procedures	
Equipment Required	5-1
Preparation	5-2
Self Calibration	5-2
Adjustment Procedure	5-3
Maintenance	
Preparation	6-1
Inspection and Cleaning	6-3
After Repair Adjustments	6-4
Repackaging Instructions	6-4
Removal and Replacement	6-9
Tools Required	6-9
Procedures	6-10
Troubleshooting Procedures	6-37
Equipment Required	6-37
General Troubleshooting Procedures	6-37
Fault Symptom Table	6-40
Troubleshooting Flowcharts	6-41

Options

Options	7-1
----------------------	------------

Replaceable Electrical Parts

Replaceable Electrical Parts	8-1
---	------------

Diagrams

Diagrams	9-1
Mainframe Interconnect Diagrams	9-1
Modules Interconnect Diagrams	9-1

Replaceable Mechanical Parts

Replaceable Parts	10-1
Parts Ordering Information	10-1
Using the Replaceable Parts List	10-2

Index

List of Figures

Figure 2–1: Location of the rear-panel power connector and configuration	2–2
Figure 2–2: Location of the CPU configuration switch	2–3
Figure 2–3: Installing the rackmount hardware	2–4
Figure 2–4: Installing the TG 2000 Platform mainframe into the rack	2–5
Figure 2–5: Instrument front panel	2–7
Figure 2–6: Browsed and selected display icons	2–9
Figure 2–7: Main display features	2–11
Figure 2–8: Module and test signal hierarchy	2–12
Figure 2–9: Selecting the Save Signals to Disk source	2–14
Figure 2–10: Selecting a Save Signals to Disk destination	2–15
Figure 2–11: Replacing test signals from disk	2–16
Figure 2–12: Selecting the source signals to add from disk	2–17
Figure 2–13: Add Signals window with source and destination selected	2–18
Figure 2–14: Rear-panel connectors	2–19
Figure 2–15: RS–232 connector pin descriptions	2–20
Figure 3–1: Simplified block diagram	3–1
Figure 3–2: Block diagram of the clocks and frame reset signals	3–4
Figure 3–3: Comparison of module delay and system delay from a reference	3–5
Figure 3–4: Block diagram of module timing delay	3–6
Figure 3–5: Block diagram of the AGL1 Reference timing delay ...	3–6
Figure 4–1: Save Signals to Disk window	4–3
Figure 4–2: New Directory window	4–4
Figure 4–3: New directory named Test	4–4
Figure 4–4: Equipment setup for verifying clock operation	4–9
Figure 5–1: Measuring the power supply voltages on the clock board	5–4
Figure 5–2: Locating parts on the clock board	5–5
Figure 6–1: Placing the module in the protective wrapping	6–5
Figure 6–2: Placing the module in the shipping carton	6–6

Figure 6-3: Placing the TG 2000 Platform mainframe in the shipping carton	6-7
Figure 6-4: Top cover removal	6-11
Figure 6-5: Removing the front-frame assembly	6-12
Figure 6-6: Removing the front-panel board and display module	6-13
Figure 6-7: Disconnecting the LCD Display module and Front Panel board	6-14
Figure 6-8: Replacing the knob encoder	6-15
Figure 6-9: Replacing the airflow regulator	6-16
Figure 6-10: Removing the floppy drive	6-17
Figure 6-11: Installing the floppy drive into the chassis	6-19
Figure 6-12: Removing the floppy drive assembly shield	6-20
Figure 6-13: Location of the Power Supply module grounding strap (SN B010391 and below only)	6-21
Figure 6-14: Removing the Power Supply module	6-22
Figure 6-15: Removing the Power Supply module attaching screws	6-22
Figure 6-16: Removing the Power Supply board	6-24
Figure 6-17: Removing the Line Filter board	6-25
Figure 6-18: Installing the fuse holder	6-27
Figure 6-19: Removing the CPU module floppy cable	6-28
Figure 6-20: Installing the CPU Memory board	6-29
Figure 6-21: Removing the date/time clock from the CPU module	6-30
Figure 6-22: Installing the Clock board oscillator	6-32
Figure 6-23: Removing the Power Supply board fan	6-33
Figure 6-24: Removing the Clock board fan	6-34
Figure 6-25: Removing the Backplane board	6-35
Figure 6-26: Replacing the battery	6-36
Figure 6-27: Instrument does not boot up properly	6-41
Figure 6-28: Measuring the power supply voltages on the clock board	6-42
Figure 6-29: Backlight does not illuminate	6-42
Figure 6-30: Measuring the LCD Display module high voltage	6-43
Figure 6-31: Front panel does not function	6-43
Figure 6-32: Locked LED does not illuminate	6-44
Figure 6-33: Floppy drive does not operate properly	6-44
Figure 6-34: Instrument is hot or the fans do not operate	6-45
Figure 6-35: Correct time is not stored	6-46
Figure 6-36: Signal noise in mainframe slots 9 and 10	6-46

Figure 6–37: Instrument loses signal and operating memory during rear-panel power off	6–47
Figure 6–38: Measuring the battery charging circuit	6–48
Figure 6–39: Front-panel knob does not function properly	6–48
Figure 9–1: Backplane board connections	9–2
Figure 9–2: CPU, Front Panel board, Power Supply board and Line Filter connections	9–3
Figure 9–3: Clock connections	9–4
Figure 9–4: AGL1 module connections	9–4
Figure 9–5: AVG1 module connections	9–5
Figure 9–6: AWVG1 module connections	9–5
Figure 9–7: BG1 module connections	9–6
Figure 9–8: GP1 module connections	9–6
Figure 9–9: DVG1 module connections (standard)	9–7
Figure 9–10: DVG1 module connections (with Option S1 installed as shipped)	9–7
Figure 10–1: Top cover and chassis assembly	10–6
Figure 10–2: Front panel, disk drive and display	10–8
Figure 10–3: Disk drive assembly	10–10
Figure 10–4: Power Supply module assembly	10–12
Figure 10–5: CPU assembly	10–14
Figure 10–6: Clock assembly	10–16
Figure 10–7: Accessories	10–18

List of Tables

Table 1–1: AC Power source	1–3
Table 1–2: Physical dimensions	1–3
Table 1–3: Environmental characteristics	1–3
Table 1–4: System clock and frame reset	1–5
Table 1–5: Certifications and compliances	1–6
Table 2–1: AC power fuse requirements	2–2
Table 2–2: Keypad definitions	2–8
Table 4–1: Test equipment required for verification	4–1
Table 5–1: Equipment List for adjustments	5–1
Table 6–1: Tools required for module removal	6–9
Table 6–2: Removal and replacement procedure list	6–10
Table 6–3: Equipment required for troubleshooting	6–37
Table 6–4: CPU confidence test codes	6–40
Table 6–5: Fault symptom table	6–40
Table 7–1: Power cord identification	7–1

General Safety Summary

Review the following safety precautions to avoid injury and prevent damage to this product or any products connected to it.

Only qualified personnel should perform service procedures.

To avoid potential hazards, use this product only as specified.

Injury Precautions

Use Proper Power Cord. To avoid fire hazard, use only the power cord specified for this product.

Avoid Electric Overload. To avoid electric shock or fire hazard, do not apply a voltage to a terminal that is outside the range specified for that terminal.

Ground the Product. This product is grounded through the grounding conductor of the power cord. To avoid electric shock, the grounding conductor must be connected to earth ground. Before making connections to the input or output terminals of the product, ensure that the product is properly grounded.

Do Not Operate Without Covers. To avoid electric shock or fire hazard, do not operate this product with covers or panels removed.

Use Proper Fuse. To avoid fire hazard, use only the fuse type and rating specified for this product.

Do Not Operate in Wet/Damp Conditions. To avoid electric shock, do not operate this product in wet or damp conditions.

Do Not Operate in an Explosive Atmosphere. To avoid injury or fire hazard, do not operate this product in an explosive atmosphere.

Product Damage Precautions

Use Proper Power Source. Do not operate this product from a power source that applies more than the voltage specified.

Use Proper Voltage Setting. Before applying power, ensure that the line selector is in the proper position for the power source being used.

Provide Proper Ventilation. To prevent product overheating, provide proper ventilation.

Do Not Operate With Suspected Failures. If you suspect there is damage to this product, have it inspected by qualified service personnel.

Symbols and Terms

Terms in this Manual. These terms may appear in this manual:



WARNING. Warning statements identify conditions or practices that could result in injury or loss of life.



CAUTION. Caution statements identify conditions or practices that could result in damage to this product or other property.

Terms on the Product. These terms may appear on the product:

DANGER indicates an injury hazard immediately accessible as you read the marking.

WARNING indicates an injury hazard not immediately accessible as you read the marking.

CAUTION indicates a hazard to property including the product.

Symbols on the Product. The following symbols may appear on the product:



DANGER
High Voltage



Protective Ground
(Earth) Terminal



ATTENTION
Refer to Manual



Double
Insulated

**Certifications and
Compliances**

Refer to the specifications section for a listing of certifications and compliances that apply to this product.

Service Safety Summary

Only qualified personnel should perform service procedures. Read this *Service Safety Summary* and the *General Safety Summary* before performing any service procedures.

Do Not Service Alone. Do not perform internal service or adjustments of this product unless another person capable of rendering first aid and resuscitation is present.

Disconnect Power. To avoid electric shock, disconnect the mains power by means of the power cord or the rear-panel power switch.

Use Care When Servicing With Power On. Dangerous voltages or currents may exist in this product. Disconnect power cord and test leads before removing protective panels, soldering, or replacing components.

To avoid electric shock, do not touch exposed connections.

Preface

You have purchased this optional service manual for the TG 2000 Platform mainframe. You can also purchase service manuals for the modules. Each module manual begins with a tab so that you can locate it after you add it to the mainframe manual binder.

The user manuals are set up the same way as the service manuals. You should receive a user manual with each mainframe or module ordered.

About This Manual

This manual contains information for servicing the TG 2000 Signal Generation Platform to a module level. The information is designed only for qualified service technicians, with moderate experience in analog circuits, digital circuits, and television technology. This manual is composed of the following sections:

- *Specifications* provides a basic product description followed by instrument specifications tables.
- *Operating Information* is designed to provide just enough operating information for a service technician to be able to service the product. For more details, refer to the user manual.
- *Theory of Operation* is an overview of the main components of the platform, describing general interactions with the modules.
- *Performance Verification* contains procedures necessary to verify that the mainframe components (Clock, Power Supply, and CPU) are meeting the requirements listed in the *Specifications*.
- *Adjustments* contains procedures to adjust the +5V power supply and the oscillator.
- *Maintenance* contains installation, removal and replacement, and troubleshooting instructions.
- *Options* lists all available options for the mainframe.
- *Replaceable Electrical Parts* for the module level are included in the Replaceable Mechanical Parts list.
- *Diagrams* contains interconnect diagrams showing the connections between the mainframe and the modules.
- *Replaceable Mechanical Parts* lists the part numbers for replacement parts that you can order. Exploded view illustrations help you to identify the parts.

Contacting Tektronix

Product Support	<p>For application-oriented questions about a Tektronix measurement product, call toll free in North America: 1-800-TEK-WIDE (1-800-835-9433 ext. 2400) 6:00 a.m. – 5:00 p.m. Pacific time</p> <p>Or contact us by e-mail: tm_app_supp@tek.com</p> <p>For product support outside of North America, contact your local Tektronix distributor or sales office.</p>
Service Support	<p>Contact your local Tektronix distributor or sales office. Or visit our web site for a listing of worldwide service locations.</p> <p>http://www.tek.com</p>
For other information	<p>In North America: 1-800-TEK-WIDE (1-800-835-9433) An operator will direct your call.</p>
To write us	<p>Tektronix, Inc. P.O. Box 1000 Wilsonville, OR 97070-1000</p>

Specifications

This section contains the *Product Description*, which describes the product and accessories, and the *Characteristics Tables*, which list the product specifications.

Product Description

The TG 2000 Signal Generation Platform provides multiformat, precision television test signals for both analog and digital video standards. The physical configuration is a mainframe with up to nine plug-in modules. Modules either generate signals or provide special functions, such as genlock capability.

You can use included software (SDP2000 Signal Development Program) to generate custom test signals, which you can store on a disk or transfer directly into the memory of a generator module.

The TG 2000 Signal Generation Platform addresses the needs of research and development, engineering, manufacturing test, and most operational environments.

These are some of the key features of the platform:

- Modular architecture with up to nine generators or special function modules
- Support of analog and digital environments for most component and composite video signal formats
- Reference generator performance level
- Modules genlocked to external reference with the optional AGL1 Genlock module
- Included Microsoft Windows-based SDP2000 software to create new signals
- Remote control, using RS-232 interface (or optional GPIB interface) and SCPI command set
- Full support of VM700A video measurement routines
- Variable transmission parameters, such as jitter amplitude and frequency, for serial digital formats using the DVG1 module with option S1
- Variable signal parameters for some analog and digital format modules
- Circle and text overlays on test signals for some modules
- Simultaneous 525/60 and 625/50 signal generation

- Moving signals for compression system testing
- Programmable system clocks to support standard and custom formats
- Flash EPROM allows easy upgrades to system software

Accessories

This section describes the key accessories for the TG 2000 Signal Generation Platform. For a complete list of accessories and their Tektronix part numbers, refer to the *Replaceable Mechanical Parts* list at the back of this manual.

BG1 Black Burst Generator Module

The BG1 Generator module is supplied as a standard accessory. There are six black burst signals to select from; the module provides the selected black burst signal on the three rear-panel connectors. Additionally, the module can provide one of the system clocks from its rear-panel clock output.

More than one BG1 Generator module can be added to the mainframe to provide enough flexibility to meet virtually any system timing requirement. The BG1 Generator module can be removed without affecting system operation.

SDP2000 Signal Development Program

The SDP2000 Signal Development Program is supplied as a standard accessory. This program runs under Microsoft Windows 3.1 or higher. All features except the parallel port are compatible with Windows NT. All features are compatible with Windows 95.

You can use the SDP2000 program to create custom signals for the various modules. You can use the remote interface or a disk to download the signals to the module memory. Refer to the *SDP2000 Signal Development Program User Manual* for information about using this program.

GPIB Card for SDP2000 Communications

The Tektronix S3FG210 is a GPIB–PCII/IIA interface card. It provides the type of interface needed to operate the TG 2000 Signal Generation Platform when performing GPIB communications with the SDP2000/TGCOMM software.

Accessory Kit

The accessory kit includes a Torx T-10 bit (needed to secure the modules), two fuses, and a blank panel. The fuses support the two line voltage settings; see *Electrical Installation* on page 2–1 for instructions. The blank panel fills the gap when a module is removed.

Extender Board

The extender board is an optional accessory that you can order to use when troubleshooting the TG 2000 Signal Generation Platform. The part number can be found at the end of the *Replaceable Mechanical Parts* list.

Characteristics Tables

This section lists the electrical and environmental specifications for the TG 2000 Platform mainframe. For the specifications of a specific module, refer to the user or service manual for that module.

Table 1-1: AC Power source

Characteristic	Performance requirement	Reference information
AC Source Voltage		
115 V operation		87 V _{RMS} to 132 V _{RMS}
230 V operation		174 V _{RMS} to 250 V _{RMS}
Power Consumption		220 W line power typical
Fuse Rating		
115V Operation		Slow blow, 6 AT
230 V Operation		Slow blow, 3 AT
Nominal Switching Frequency		100 kHz

Table 1-2: Physical dimensions

Characteristic	Description
Dimensions	Height: 5.25 in (13.34 cm) Width: 19.0 in (48.26 cm); standard rack width Depth: 23 in (58.42 cm)
Weight ¹	Net Weight: 38 lbs (17.27 kg) typical Shipping Weight: 52 lbs (23.67 kg) typical

Table 1-3: Environmental characteristics

Characteristic	Performance requirement	Reference information
Temperature		
Operating	32° F to 104° F (0° C to 40° C)	
Nonoperating	-4 to +140° F (-20 to +60° C) ²	

¹ Weight of the TG 2000 will vary depending on the number and type of generator or other modules installed.

² Battery storage life is specified at 25° C. At 60° C, battery discharge accelerates, resulting in self discharge in less than 30 days.

Table 1–3: Environmental characteristics (cont.)

Characteristic	Performance requirement	Reference information
Altitude		
Operating	To 15,000 feet (4572 meters)	
Nonoperating	To 40,000 feet (12,203 meters)	
Humidity		
Operating	≤ 104° F (≤ 40° C), up to 95% relative humidity	
Nonoperating	Up to 95% relative humidity	
Heat Dissipation		220 Watts maximum for mainframe with modules in all slots
Clearance for Cooling		For rack installation, allow standard side cooling and 2 in (5 cm) rear clearance for cables For desktop use, allow 2 in (5 cm) side and rear clearance
Bench Handling	1 drop of 2 inches of each edge for all significant surfaces	
Vibration		
Operating	5-100 HZ g2/Hz APSD: 0.00015 100-200 Hz Slope dB/Octave: 0 200-350 HZ g2/Hz APSD: 0.00015 350-500 Hz Slope dB/Octave: -3 500 HZ g2/Hz APSD: 0.000105 GRMS overall: 0.27[0.24] Time/Axis minutes: 10	
Nonoperating	5-100 HZ g2/Hz APSD: 0.0175 100-200 Hz Slope dB/Octave: -3 200-350 HZ g2/Hz APSD: 0.00875 350-500 Hz Slope dB/Octave: -3 500 HZ g2/Hz APSD: 0.006132 GRMS overall: 2.22 Time/Axis minutes: 10	
Mechanical Shock, Nonoperating	30 g 1/2 sine, 11 ms duration 3 shocks per surface (18 total)	

Table 1–3: Environmental characteristics (cont.)

Characteristic	Performance requirement	Reference information
Transportation		Package qualified per Tektronix standard 062–2858–00 Rev. B “Environmental Test Methods–Dynamics” and MBD Quality Document ENVL–0060 “Transportation Package Qualification Test Plan”.
Equipment Type		Test and Measuring
Equipment Class		Class 5

Table 1–4: System clock and frame reset

Characteristic	Performance requirement	Reference information
Clock Frequency		27 MHz DDS Ch 1: 10 MHz to 100 MHz DDS Ch 2: 10 MHz to 100 MHz Step Size: ≤ 0.1 Hz
Stability	± 1 ppm/year, operating at standard oven temperature	
Clock Jitter		≤ 30 ps RMS
Non-harmonic Clock Spurs		-45 dBc or better
Tune Range		± 10 ppm
Frame Reset		Two reset channels, 1.7 Hz to 1 kHz

Table 1-5: Certifications and compliances

Category	Standard
EC Declaration of Conformity	<p>Compliance was demonstrated to the following specifications as listed in the Official Journal of the European Communities:</p> <p>EN 50081-1 Emissions: EN 55022 Class B Radiated and Conducted Emissions EN 60555-2 AC Power Line Harmonic Emissions</p> <p>EN 50082-1 Immunity: IEC 801-2 Electrostatic Discharge Immunity IEC 801-3 RF Electromagnetic Field Immunity IEC 801-4 Electrical Fast Transient/Burst Immunity IEC 801-5 Power Line Surge Immunity</p>
	<p>Low Voltage Directive 73/23/EEC, Amended by 93/68/EEC</p> <p>EN61010-1 Safety Requirements s for Electrical Equipment for Measurement, Control, and Laboratory Use</p>
Safety	
U.S. Nationally Recognized Laboratory Listing	ANSI/ISA S82.01 Safety Standard for Electrical and Electronics Test, Measuring, Controlling, and Related Equipment, 1994
Canadian Certification	CAN/CSA C22.2 No. 1010.1 Safety Requirements for Electrical Equipment for Measurement, Control, and Laboratory Use
European Union	<p>Low Voltage Directive 73/23/EEC, Amended by 93/68/EEC</p> <p>EN61010-1 Safety Requirements for Electrical Equipment for Measurement, Control, and Laboratory Use</p>
Additional Compliance	<p>UL3111-1 Standard for Electrical Measuring and Test Equipment</p> <p>IEC1010-1 Safety Requirements for Electrical for Measurement, Control, and Laboratory Use</p>
Safety Certification Compliance	
Temperature, operating	41° F to 104° F (+5 to +40° C)
Altitude (max operating)	6562 feet (2000 meters)
Equipment Type	Test and Measuring
Safety Class	Class I (as defined in IEC 1010-1, Annex H) – grounded product
Overvoltage Category	Installation Category II (as defined in IEC 1010-1, Annex J).
Pollution Degree	Pollution Degree 2 (as defined in IEC 1010-1). Rated for indoor use only.

Operating Information

This section contains the following information:

- Installation instructions
- Operating information

All modules that you order are shipped configured and installed in the TG 2000 Platform mainframe. Refer to *Options* on page 7–1 for information about any installed options. To install or remove a module, refer to the user or service manual for that specific module.

Installation

Before you install the TG 2000 Platform mainframe, observe these environmental considerations:

- Provide the appropriate operating environment. Refer to *Specifications* for temperature, humidity, altitude, and other environmental requirements.
- Leave enough space for instrument cooling by ensuring standard side clearance for rackmount installation or 2 inches (5.1 cm) of side clearance for countertop use.
- Ensure rear clearance of approximately 2 inches (5.1 cm) so that cables are not damaged by sharp bends.

Electrical Installation

To install the TG 2000 Platform mainframe, perform these steps:



WARNING. To avoid electrical shock, be sure that the power cord is disconnected before checking the fuse or changing the setting of the Line Selector switch.

To avoid damaging the TG 2000 Platform mainframe, always use the correct fuse for the local line voltage. Refer to Table 2–1 on page 2–2 or the fuse chart located on the rear panel for the proper fuse rating for each line voltage setting.

1. Using the information in Figure 2–1, set the rear-panel Line Selector switch to the correct position for your local AC power system.
2. Check that the correct line-voltage fuse for your local AC power system is installed. Refer to Table 2–1 for the fuse ratings.

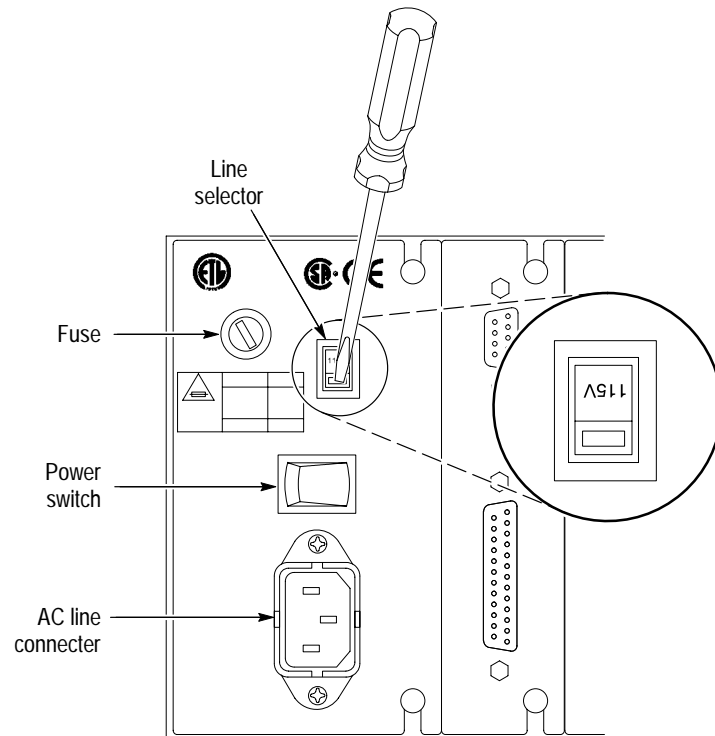

Figure 2-1: Location of the rear-panel power connector and configuration

Table 2-1: AC power fuse requirements

Line Voltage Setting	Fuse Rating
115 V	250 V, 6 AT
230 V	250 V, 3 AT

3. Check that the CPU configuration switch is in the “0” position. See Figure 2-2.
4. Check that you are using the correct power cord for the local AC power system. Refer to *Options* on page 7-1 for a list of power cords.
5. Connect the power cord from the rear-panel power connector to the AC power system.

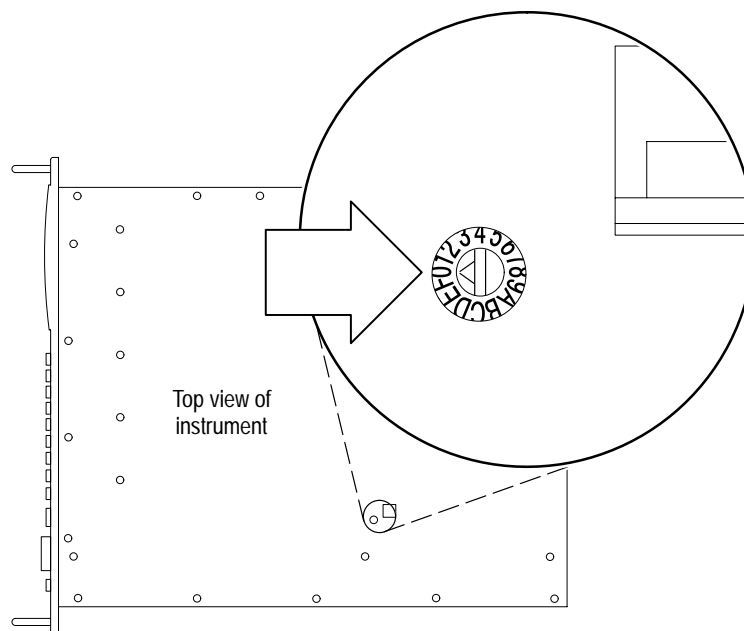

Figure 2-2: Location of the CPU configuration switch (switch set to 0)

Rackmount Installation

To rackmount the TG 2000 Platform mainframe, perform the following steps:

1. Connect the rackmount hardware to the rack, as shown in Figure 2-3.
2. Carefully begin inserting the rack pieces attached to the TG 2000 Platform mainframe into the pieces attached to the rack. See Figure 2-4.



WARNING. To prevent the TG 2000 Platform mainframe from falling and causing injury to yourself and damage to the instrument, be sure that the stop latches snap into position in the slide-out track on both sides of the instrument. See Figure 2-4.

3. Support the instrument until the stop latches click into place on both sides.
4. Continue to slide the TG 2000 Platform mainframe completely into the rack.

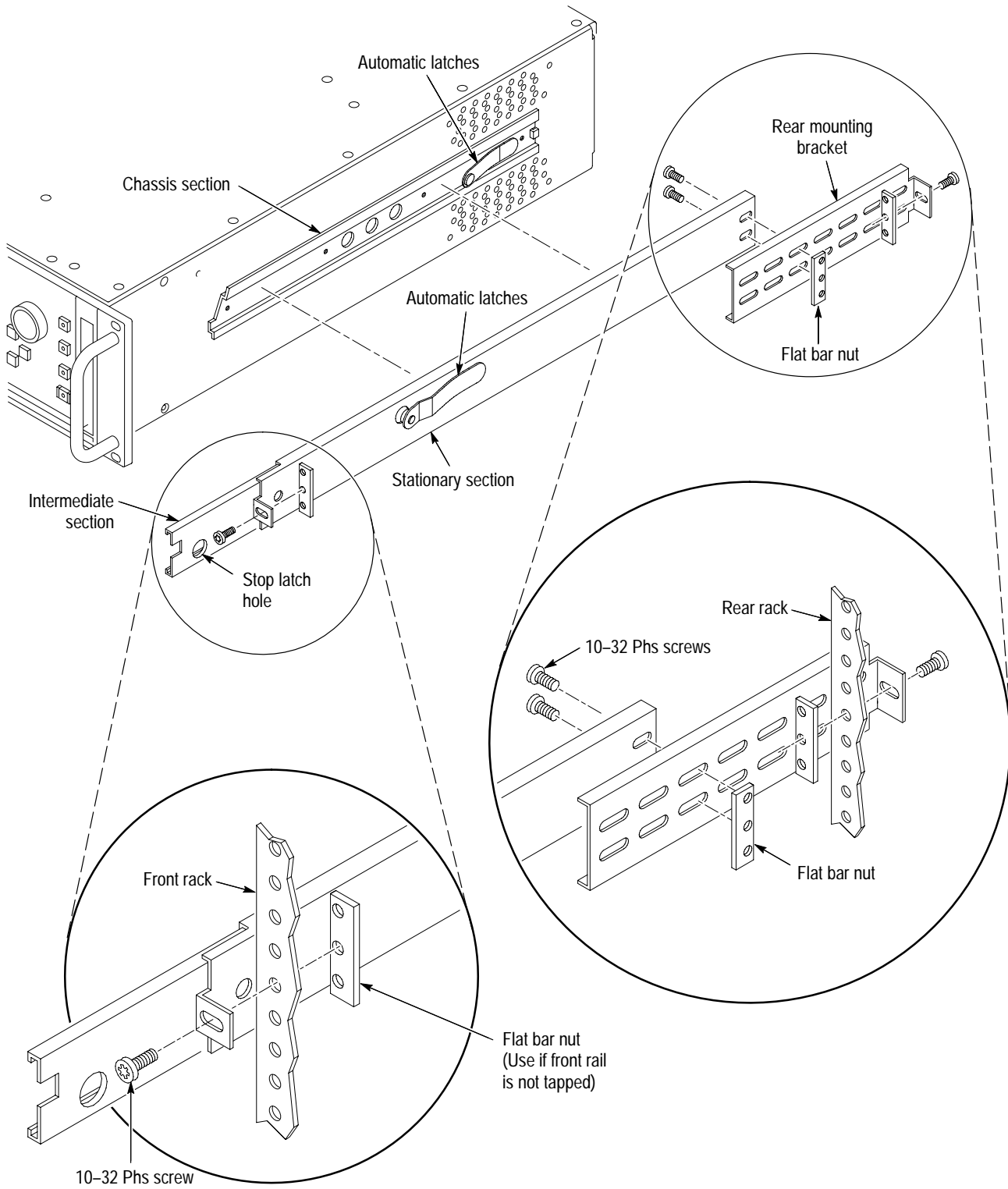

Figure 2-3: Installing the rackmount hardware

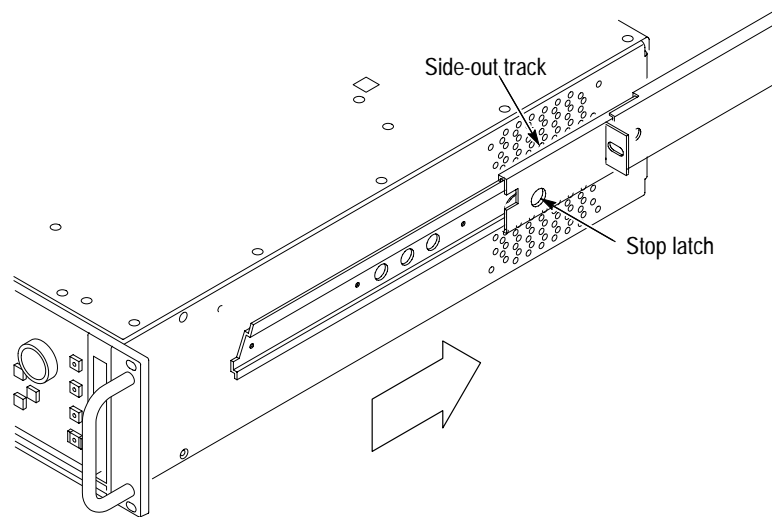

Figure 2-4: Installing the TG 2000 Platform mainframe into the rack

Rackmount Removal. Perform these steps to remove the TG 2000 Platform mainframe from the rack:

1. Disconnect the power cord and any attached cables from the rear of the instrument.
2. Slide the TG 2000 Platform mainframe out until it stops at the catches.



WARNING. To prevent the TG 2000 Platform mainframe from falling and causing injury to yourself and damage to the instrument, be sure that the stop latches snap into position in the slide-out track on both sides of the instrument.

3. Support the TG 2000 Platform mainframe while you depress the stop latch buttons on each side of the instrument. See Figure 2-4.
4. Provide support while you slide the TG 2000 Platform mainframe completely out of the rack.

Operating Information

This section contains instructions and procedures that will acquaint you with the basics of operating the TG 2000 Platform mainframe so that you can perform service on the instrument. Refer to the *TG 2000 Signal Generation Platform User Manual* for detailed operating information.

This section includes instructions on the following topics:

- Front-panel controls and indicators (page 2–6)
- Using the touch screen (page 2–10)
- Selecting test signals (page 2–12)
- Using the disk drive (page 2–13)
- Self Calibration (page 2–18)
- Rear-panel connections (page 2–19)
- Power-on procedure (page 2–21)

The primary method to control the TG 2000 Signal Generation Platform is to use a combination of front-panel button and LCD display touch screen selections to activate the functions within the instrument.

The secondary method to control the instrument is through the remote ports. Refer to the user manual for detailed remote instructions.

Front-Panel Controls and Indicators

The front-panel controls (see Figure 2–5) are divided into the following functional sections:

- System function
- Keypad
- Navigation
- Miscellaneous function

After you select an instrument function, the selection may require a few seconds to implement. A small hourglass icon is displayed in most cases while the instrument implements your selection. Wait until the hourglass icon disappears before you make another selection.

System Function. In most cases, when you push one of the System Function buttons, a window opens on the LCD display providing touch-screen selections related to the function of the button. For example, the Modules button displays a window with selections that represent the installed generator modules.

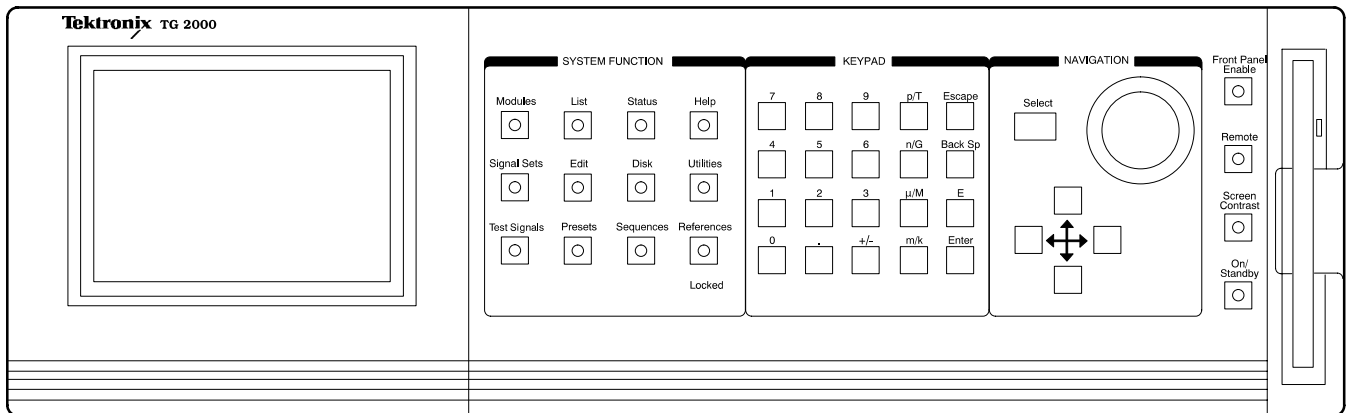

Figure 2–5: Instrument front panel

The following buttons and windows are useful when you have a question about the operation of the instrument:

- **Help.** Displays a window that explains details about the displayed window.
- **Status.** Displays the following information about all installed modules: module type, name, slot location, format, and output signal.

The status of an installed AGL1 module is listed at the bottom of the display. System problems, such as a module failing the power-up self test, are also displayed in the Status window.

- **Utilities.** Provides access to the following housekeeping functions and information: date and time, versions of installed modules, front-panel timeout period, self calibration, clock clients, and frame-reset clients. Refer to page 2–18 for a self calibration procedure.

The Locked LED (located below the References button) has three states to indicate the status of the genlock function.

- **Illuminated.** The instrument is locked to the external reference.
- **Blinking.** The instrument is attempting to lock or is unable to lock to the external reference. Check that the incoming signal matches the type chosen in the Reference Select window. Also, ensure that the signal line is properly terminated at the AGL1 loop-through connector or at the distant equipment connection. The status bar gives the current status.
- **Off.** The instrument reference selector Int/Ext is set to Internal and the AGL1 module is not active, or the AGL1 module is not installed.

Keypad. Use the keypad to enter an exact quantity for a parameter. Use the scale keys, such as k (kilo) and M (mega), to enter specific values. Table 2–2 shows the purpose of each key.

Table 2–2: Keypad definitions

Key(s)	Function
0–9	Enters numeric values
.	Enters a decimal point
+/-	Toggles the numeric value between positive and negative
p/T	Enters the pico or Tera unit of measure ¹
n/G	Enters the nano or Giga unit of measure ¹
μ/M	Enters the micro or Mega unit of measure ¹
m/k	Enters the milli or kilo unit of measure ¹
Escape	Exits out of data entry mode without changing the existing data
Back Sp	Erases one character
EE	Allows exponent entry. When entering a parameter value, enter a number, press the EE key, and then enter the exponent value. For example, press 4.2 EE 6 to enter the value 4.2×10^6 .
Enter	Changes the parameter value to the new value

¹ The instrument determines which of the two units is appropriate based on the parameter being set.

Navigation Controls. The following navigation controls provide an alternative method to touching onscreen display items to select them:

- **Arrow Buttons.** Use these buttons to navigate through lists and objects on the display and to move the cursor when entering text.
- **Knob.** Use the knob to scroll through a list or to change a parameter setting. Turn the knob to browse items in a window and to select characters in a text entry window. When you have a numeric item selected, the knob will change the value for the selected parameter. When you change a parameter, the module output changes immediately.
- **Select.** Use the Select button to confirm an entry or to make a browsed selection active. Push the Select button repeatedly to sequence through items within an icon when it contains several selections.

Touching a display item immediately activates the item. You can use the arrow buttons and knob to move from item to item on the display without activating them. This technique is known as *browsing*. To activate a browsed item, push the Select button or touch the browsed display icon. See Figure 2–6.

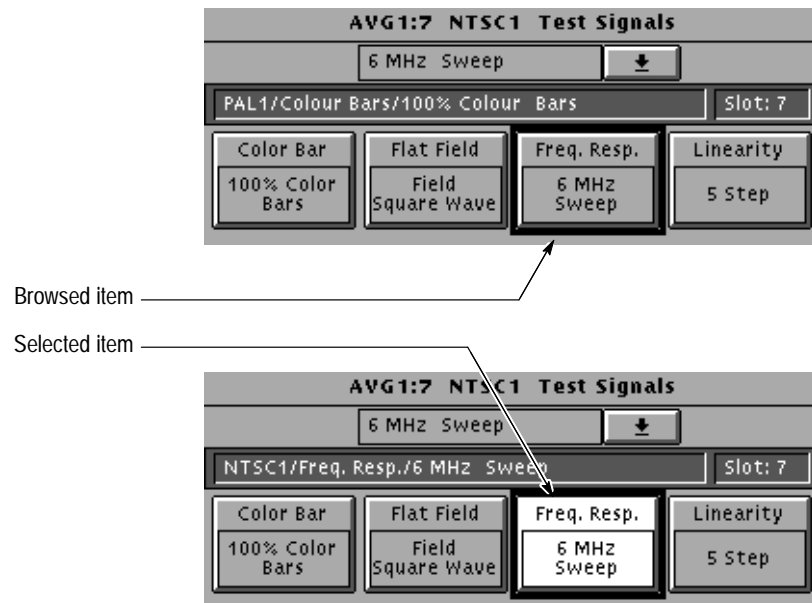

Figure 2-6: Browsed and selected display icons

Miscellaneous Function Buttons. The four buttons at the right edge of the front panel provide the following functions:

- Front Panel Enable. This button acts like a toggle switch to enable (LED on) or disable (LED off) the front-panel keys, the knob, and the touch screen.

NOTE. The instrument turns the display off and disables the front-panel controls when the front panel is not used for the specified timeout period. Push the Front Panel Enable button to enable the front panel after it has timed out. Push the Utilities button to access the timeout delay settings.

- Remote. Push the Remote button to access control of the remote interfaces through the Remote window. The following areas of control are available:
 - Serial Setup. This selection provides control of the serial RS-232 interface.
 - Parallel Setup. This selection provides control of the parallel interface.
 - Remote Only. This selection locks out the front-panel controls when remote-only operation is desired. Touch the Quit icon in the Remote Only window to return to front-panel operation.
 - Remote Port. This selection selects an interface port. You must select an interface port before using it for transferring data or commands. Touch the Remote Port icon repeatedly to cycle through the selections.

- **GPIB Setup.** This selection lets you set the GPIB configuration. This selection is only available when the GP1 module is installed.
- **Screen Contrast.** When screen contrast is active (LED on), rotate the knob to adjust the screen contrast for the best viewing in your environment.
- **On/Standby.** Push the On/Standby button (LED on/LED off respectively), to turn the instrument off after all critical processes have been completed. This leaves the instrument in a known state. The On/Standby button is different than the rear-panel power switch, which immediately shuts off power to the instrument regardless of any functions that are in process.

When the On/Standby button is set to On, the battery system charges at the highest rate. When the button is set to Standby and the rear-panel power switch is on, the battery system charges at a low or trickle rate.

Using the Touch Screen

The LCD display serves as a touch screen that lets you touch display icons to make functional selections. Touching a display icon either selects the item or displays additional selections.

The following features appear in the touch-screen windows. See Figure 2–7.

- **Icons.** Icons are display symbols that represent and show the status of test signals or other selectable items. Touching some display icons repeatedly cycles through the available selections.

NOTE. *Icons of the same function can appear as selections in more than one window. For convenience, icons appear where they are functionally appropriate.*

- **Status Bar.** The Status Bar shows the active signal set and test signal for the selected module (BG1:2 in Figure 2–7). The status bar also gives the status of other functions, such as signal transfers.
- **Window Title.** The Window Title shows the window name, which indicates the selected function.
- **Slot: #.** The slot number identifies the physical location of the selected module to remind you which module outputs are being controlled. In Figure 2–7, note that the slot # matches the “2” in the active module name, BG1:2.
- **List box.** Touch the List Box to show additional selections that are available within a display icon, such as a list of test signals. To display the list box selections, rotate the knob or touch the list box. To select a list box item, use the cursor keys or the knob to highlight a selection, and then push the Select button. Touch an open list box to close it without making a selection.

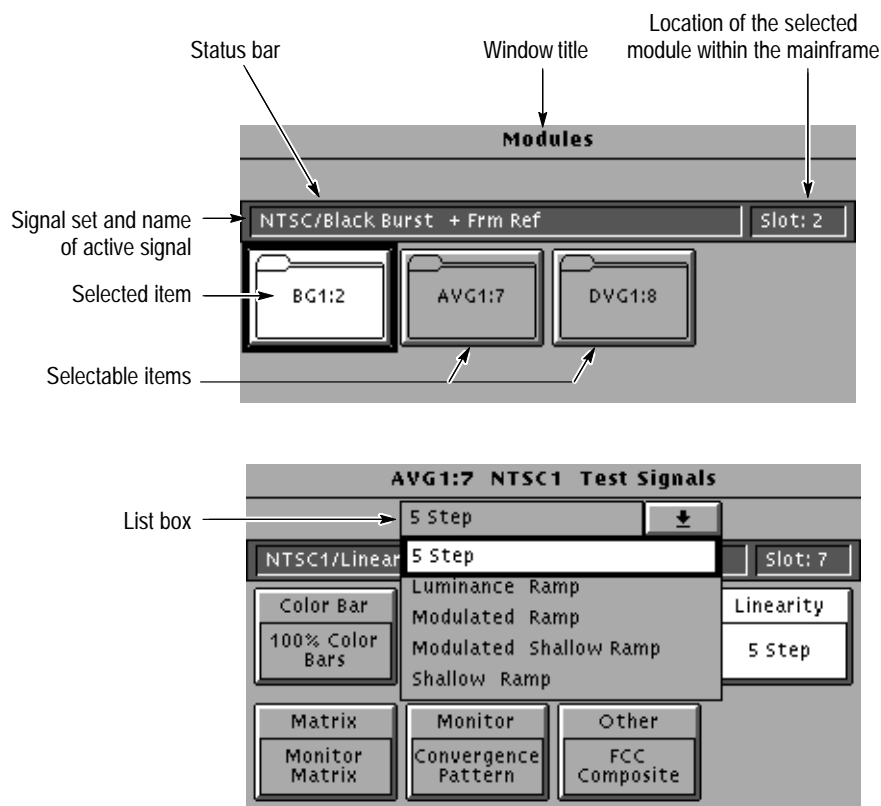

Figure 2-7: Main display features

- Page or << Page >>. Touch the Page icon to access the previous or following page of display selections.
- Quit/Save. Touch the Quit or the Quit/Save icon to return to a previous display window. If you have made changes, you will be asked if you want to save them. If you have changed a test signal, you will be prompted to enter a signal name. The signal name you enter will always be preceded by an underscore character to indicate a user-created test signal.
- Reset. Touch the Reset icon to return a parameter setting to the value it had when you entered the window.
- Hourglass. A small hourglass icon is displayed in most cases when the instrument is taking time to implement your selection. Wait until the hourglass icon disappears before you make another selection.

Selecting Test Signals

The System Function buttons named Module, Signal Sets, and Test Signals provide access to the output signals. These buttons allow you to select a module, a signal set within the module, and a particular test signal. After selecting a test signal, you can set common module parameters and signal parameters for individual signals. Figure 2–8 shows this test signal hierarchy.

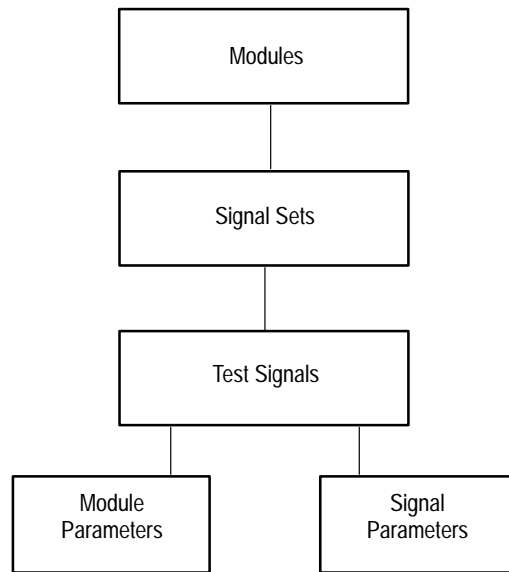

Figure 2–8: Module and test signal hierarchy

Each module has a Module Parameters selection for parameters that apply to all appropriate test signals from that module. Each test signal also has unique parameters controlled through the Signal Parameters icon.

Shared Module Memory. Generator modules of the same type share their onboard memory spaces to provide larger signal-storage areas. Signals stored on one module can be loaded and output by other modules of the same type.

When you remove a module, the signals stored on the module are no longer available to the remaining modules. Before removing a module, copy all signals for the module type to a floppy disk. After removing the module, you can reload removed signals from the disk providing there is enough free memory space to load the signals.

Using the Disk Drive

The disk drive provides a way to load and save signal sets and sequences for a module. You can also save all current settings, called presets, for the mainframe and its modules to the disk. The disk drive uses 3.5 inch, 1.44 Mbyte, MS-DOS-formatted disks. The disks must be formatted before using them in the drive.

Supported File Types. The disk drive reads and writes several types of files that support different functions. The following file types are supported:

- **Signal Sets.** These files contain directories of signal groups and, at the lowest level, test signals. Signal set files have a .dnl suffix and may contain test signals for more than one type of module. Use the SDP2000 Signal Development Program software to create signal sets and assign them to a module type. You can also save signal sets from a module to the disk.
- **Presets.** These settings files are stored in a special binary format that is unique to each type of module. The settings can be saved to disk and restored later.
- **Sequences.** These are TCL files stored as ASCII text, which is readable by any text editor. Sequence files contain a series of SCPI and TCL commands that are entered using a text editor. Sequence files have a .seq suffix.

To specify a sequence file to run at instrument power on, load a sequence file named AUTOSTRT into the instrument. At power-on, the instrument checks the disk drive first and then the internally-stored sequence files for one named AUTOSTRT. The instrument will automatically execute the contents of the first AUTOSTRT file it finds.

Saving Signals to Disk. Test signals that can be output from a module can be saved onto a disk. You should save all signals in a module to a disk before removing the module. Modules will lose their signal memory after 30 seconds when you remove them from the mainframe.

To save signals to a disk, follow these steps:

1. Insert a preformatted disk into the drive. Ensure that the disk is not write protected.
2. Push the Disk button to open the Disk window and then touch the Save Signals to Disk icon.
3. Touch the Select Source icon to display a window like the one in Figure 2–9.
4. Select a module type (such as **AVG1** at the left of the display) by highlighting it with the arrow buttons, and then pushing the Select button. Move right to select the signals you want to save to a disk file.

Signals are displayed in a hierarchical list with the top of the list shown at the left under the Signals header. The value Total Tagged: is the combined size of the selected signals.

If there are more signals than will fit on one disk, use multiple disks and select a smaller group of signals to save on each disk.

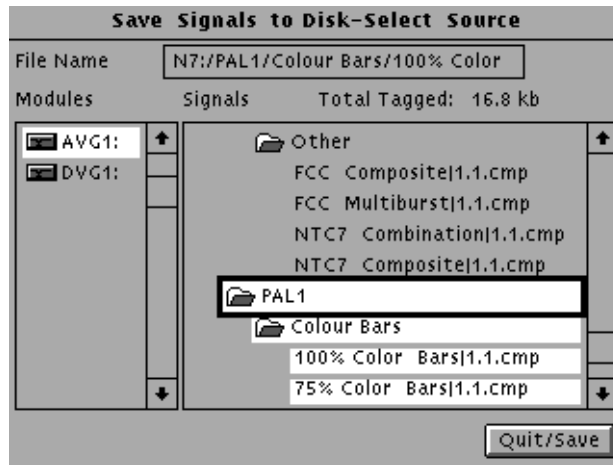

Figure 2-9: Selecting the Save Signals to Disk source

5. Touch Quit/Save when you have selected the signals to save to disk.
6. In the Save Signals to Disk window, touch Select Destination.
7. You can use the New Dir icon to create a directory on the disk. Otherwise, touch the New File icon and give the output file a name. In Figure 2-10, a directory named local was created, and then a file named test1 was created.
8. When the source and destination of the test signal are entered, you can save the signals to disk. Touch the Start Save icon to begin the save process. Saving signals to disk takes a brief length of time that depends on the number and size of the signals you are saving.

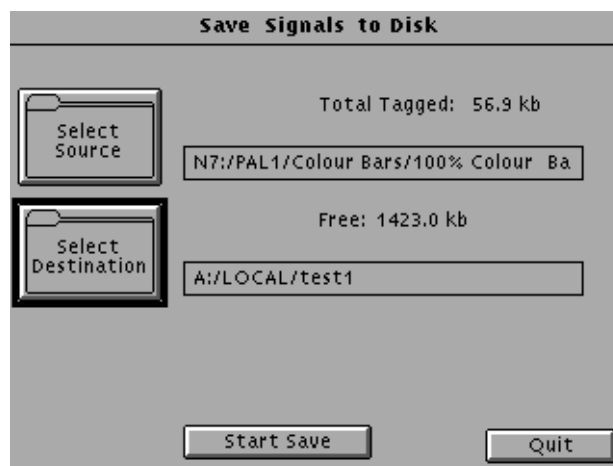

Figure 2–10: Selecting a Save Signals to Disk destination

Replacing Signals from Disk. You select Replace Signals from the Disk window to load new signals in place of the currently installed signals for a module type, such as the AVG1.



CAUTION. To prevent data loss, use caution with the Replace Signals function. All signal sets currently loaded in the selected module type are DELETED, and the replacement signals are then loaded into the selected module type. You should consider saving all the signals in a module type to disk before using the Replace Signals function.

Follow these steps to replace all signals for a type of generator module, such as all installed AVG1 modules, with signals from a disk:

1. Insert a disk containing the signal sets into the disk drive.
2. Push the Disk button to open the Disk window, and then touch the Replace Signals icon.
3. Use the arrow buttons to highlight the signal file you want to load, and then press the Select button. In Figure 2–11, the file TEST1.DNL is selected.
4. Touch the Quit icon after you have selected the signal file.
5. The signals contained in the signal file (TEST1.DNL in this example) are displayed in a hierarchical structure. Use the arrow buttons to select the signals that you want to load. The displayed value Available: indicates the free module memory remaining after the selected signals are loaded.
6. Touch the Start Replace icon to load the selected signals into the memory of the compatible modules.



Figure 2-11: Replacing test signals from disk

Adding Signals from Disk. To add signals to a module from the disk drive, follow these steps:

1. Insert the disk with the test signals into the disk drive, and then push the Disk button to open the Disk window.
2. Touch the Add Signals icon, and then touch Select Source.
3. Select the signal set file from A: drive and then touch the Quit/Load icon.
4. Select the signals that you want to add from the signal set file. In Figure 2-12, the Linearity signals under PAL1 are selected. When you have selected the signals you want to add, touch the Quit/Load icon, and then touch Quit/Load again to return to the Add Signals window.

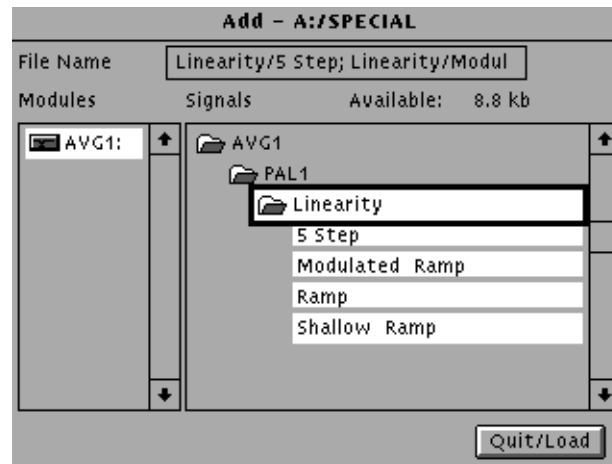

Figure 2–12: Selecting the source signals to add from disk

5. Touch the Select Destination icon, and then select the type of destination module. If you are loading a single test signal, select the destination at the top of the hierarchy and it will be placed in an appropriate lower folder. You can also pick a bottom level folder for the destination.

If a mismatch between the source and destination hierarchy occurs, the following error appears: “This selection is too deep given the source.” Try a destination at a higher level in the hierarchy and let the TG 2000 Platform mainframe pick the appropriate level to add the signal.

6. When you have selected the destination for the test signal you are adding, touch the Quit/Load icon to return to the Add Signals window.
7. In Figure 2–13, the source file SPECIAL is selected from the disk drive. The destination module type is AVG1, and the point in the hierarchy is PAL 1.

Note that the value Total Tagged: is the size, in kilobytes, of the files to be loaded. The value Free: is the size, in kilobytes, of the free memory space on the AVG1 module. If the Tagged value exceeds the Free value, the module will not have enough memory space to contain the new signals. Reduce the number of signals being loaded (Select Source) or delete a few signals from the module (Delete Signals) to free signal space.

8. Touch the Start Load icon to transfer the signals into the destination module.

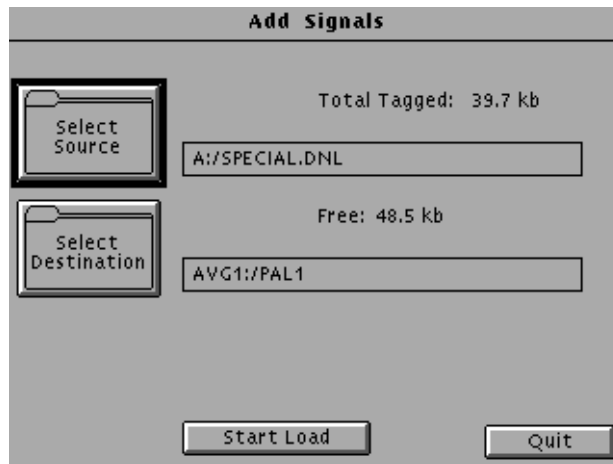

Figure 2-13: Add Signals window with source and destination selected

Deleting Signals. To delete signals from a module, follow these steps:

1. Push the Disk button to open the Disk window and then touch the Delete Signals icon.
2. Select the test signals or signal sets you want to delete. The value Total Tagged: indicates the memory used by the selected signals.

Note that the custom signal files you create contain only signal-difference data referenced from an original signal. The custom signals have a .sig suffix and cannot be deleted without deleting the original signal.

3. Touch the Delete icon to remove the selected signals from the module.

Self Calibration

This function performs an auto calibration of the selected modules. Self calibration does not require any external test equipment, though all output connections of the modules to be calibrated must be terminated into 75 Ω .

Perform self calibration on a module anytime it has been replaced to ensure proper performance of the generator. Refer to the module user manual for information about any special setup necessary before starting self calibration.

NOTE. All installed modules have their outputs disabled during the calibration of any module.

Allow a 20 minute warm-up period before performing self calibration.

To calibrate one or more modules, follow these steps:

1. Push the Utilities button and touch the Module Self Cal icon.
2. Touch the module icons that you want to calibrate. Any or all modules may be selected for calibration.
3. Ensure that all signal outputs for the selected modules are properly terminated into 75 Ω . (You do not need to terminate the Trigger outputs of any module and the BG1 module outputs.)
4. Touch the Start Cal icon to begin calibration of the selected modules. The number of modules selected determines the time required for calibration.
5. Check that no errors are displayed during calibration. Refer to *Maintenance* on page 6–37 for troubleshooting information.

Rear-Panel Connections

Figure 2–14 shows the rear-panel connections for the TG 2000 Platform mainframe. Connections to modules in slots 2 through 10 are discussed in the appropriate module user manuals.

You must select an interface port before using it. To select the interface port, push the Remote button, and then touch the Remote Port icon repeatedly to cycle through the available choices.

AC Power. For important information on the AC power connection, fuse, and line selector, refer to *Electrical Installation* on page 2–1.

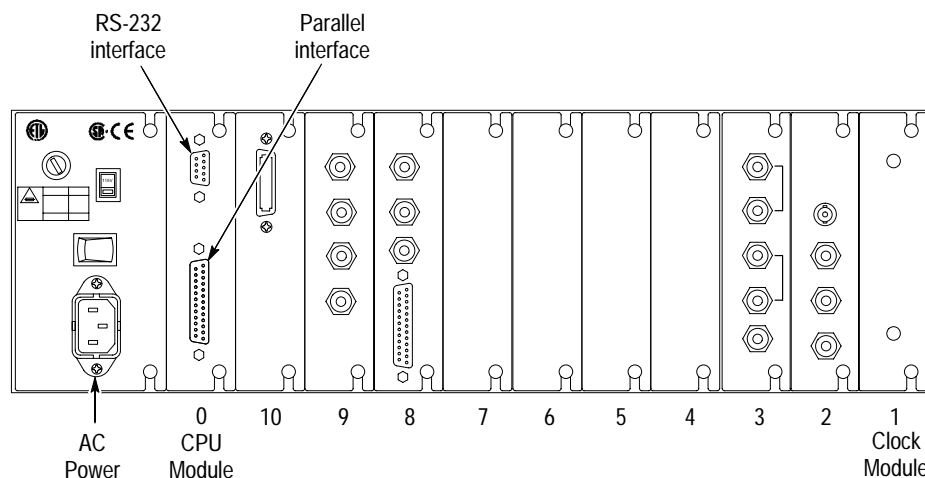

Figure 2–14: Rear-panel connectors

RS-232 Interface (Serial). This is a standard RS-232 interface for remote control of the TG 2000 Platform mainframe and all installed modules. The RS-232 connector (on the CPU module) is a 9-pin, subminiature, D-type connector with male contacts. The pin descriptions are shown in Figure 2–15.

To use the interface, connect the 9-pin serial/RS-232 output of your PC to the 9-pin RS-232 connector on the rear panel of the mainframe, using a 9-pin-to-9-pin straight-through cable. If necessary, a 25-pin connector can be used, in conjunction with a 9-pin-to-25-pin adapter.

Refer to the *TG 2000 Signal Generation Platform User Manual* for programming information.

	Pin number	Data connection at TG2000 mainframe rear panel
	1.	Not used
	2.	RXD (Received Data)
	3.	TXD (Transmitted Data)
	4.	Not used
	5.	Ground
	6.	DSR (Data Set Ready)
	7.	RTS (Request To Send)
	8.	CTS (Clear To Send)
	9.	Not used

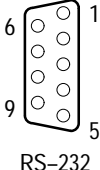

Figure 2–15: RS-232 connector pin descriptions

Parallel Interface. The parallel interface is a 25 pin D-type connector on the CPU module. The main purpose of the Centronics-compatible port is for transferring signal sets from the SDP2000 Signal Development Program software into the generator modules.

NOTE. For proper operation of the parallel interface, ensure that all 25 connector pins are connected straight through your cable.

GPIB Interface. The optional GP1 Interface module provides a GPIB interface. For information on this interface, refer to the *GP1 Interface Module User Manual*.

Power-on Procedure

The following procedure describes how to check that the TG 2000 Platform mainframe powers on properly.

1. Before applying power to your TG 2000 Signal Generation Platform, check the following items:
 - a. Check for proper installation. Refer to *Installation* on page 2–1.
 - b. Check that the power cord is connected to the AC line source.
2. Set the rear-panel Power switch to on.
3. Push the front-panel On/Standby button to apply power.

During power-on, the TG 2000 Platform mainframe performs a self test to verify functionality. The self test requires a minute or less to complete, depending on the number of modules installed. The front-panel display will be on with no displayed errors after the self testing successfully completes.

If your TG 2000 Platform mainframe powers on, but an installed module fails to appear in the Modules window, refer to *Maintenance* for troubleshooting instructions.

4. Once the power-on self tests are complete, the TG 2000 Platform mainframe recalls the settings that were active when the instrument was powered off. The power-on settings are stored in nonvolatile memory.
5. When you first power on the TG 2000 Platform mainframe after shipment or long storage, leave the front-panel On/Standby button set to on (LED on) for 12 hours to fully charge the system batteries. The batteries maintain the test signal data NVRAM when the mains power is disconnected.

NOTE. *If backup power is lost, you must reload the test signal data into NVRAM from the disks supplied with your user manual or through a remote port. After reloading the test signal data, run a self calibration on all modules.*

Theory of Operation

This discussion provides an overview of the main components of the TG 2000 Signal Generation Platform. This discussion covers general interactions with the modules. For information about a specific module, refer to the user manual for that module.

Block Level Description

Figure 3–1 shows a simplified block diagram of the TG 2000 Signal Generation Platform

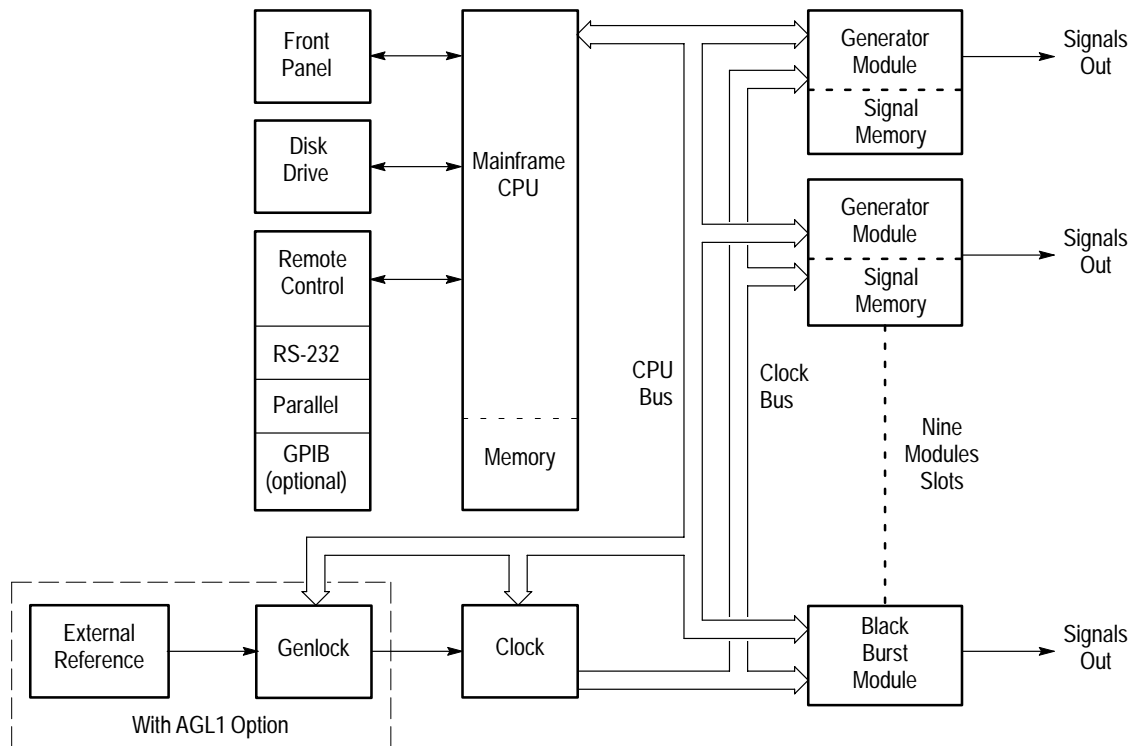

Figure 3–1: Simplified block diagram

System Control

As shown in Figure 3–1, the mainframe CPU coordinates front panel and remote interface commands and uses that input to set up the modules, the clock, and the optional AGL1 Genlock module. The CPU sends data and control messages over the CPU bus to set up the generator modules to perform a function, such as load a test signal into module memory or change the output configuration.

- Power Supply** The 220 W power supply has a rear-panel switch to select between 115 V and 230 V operation.
- The power supply delivers voltages to the various modules and mainframe components and to the two cooling fans. The rear-panel switch is a hard power switch, while the front-panel switch is a soft power switch.
- Disk Drive** The disk drive provides an easy way to load signal sets, presets, sequences and other data. It also provides a way to export the same types of data. The drive supports 1.44 Mbyte, MS-DOS format disks. The complete signal sets for each module type are shipped with the module on 3.5 inch disks.
- Remote Control** Most front-panel control functions can be remotely controlled using the RS-232 or optional GPIB port. A computer or other controller sends SCPI compatible commands to set up the mainframe or a specific module. Each module must be individually set up, using its own set of commands. The mainframe and modules use some of the same commands, but each also has unique commands. The SCPI command set for each module is described in section 3 of the module user manual.
- Generator Modules** There are eleven module slots in the mainframe. The Clock and CPU modules are required for system operation and permanently occupy two special slots (they must be installed in these slots). The BG1 Black Burst Generator module is also a standard component of the mainframe, but it can be moved or replaced with another module if desired. Without the BG1 Generator module, optional AGL1 Genlock module or optional GP1 Interface module, there is room for nine generator modules. Any combination of different generator modules and/or multiples of the same generator module may be used.
- Signal Memory** Most generator modules contain NVRAM for storing test signals. The test signals are initially loaded from the supplied disks or through the parallel or RS-232 port into NVRAM. The signal that is selected for output is loaded into fast memory on the module. The loaded signal configures the module to immediately output the selected signal. The flexible memory architecture allows one generator module to output signals stored on another module of the same type. Installing four of the same type of module, such as the AVG1 Generator module, provides four times the signal storage space. All four modules have equal access to this expanded memory space.
- Battery Backup for NVRAM** A central rechargeable battery maintains NVRAM data in the mainframe and modules when AC power is not connected. The power supply quick charges the battery while the instrument power is on. When the instrument is turned off using the front-panel On/Standby switch, the battery is trickle charged. The battery is not recharged while the rear-panel power switch is off.

The power drain on the battery is low enough to allow module memory to remain intact for many months. When you add more modules or modules that use more power, the length of time that the memory remains intact is shortened.

In the event of memory failure from power loss, reload the signal memory (NVRAM) from the supplied disks or through a remote port, and then run self cal on all modules.

NOTE. When you first turn on the mainframe, leave it turned on for at least 12 hours to fully charge the backup battery. Do this also after you replace the backup battery.

Clocks and Frame Reset Signals

The 27 MHz master clock synchronizes the clocks and frame reset pulses that control module timing, as shown in Figure 3–2. The Clock module provides three high-speed clock signals, one at 27 MHz, and two at rates from 10 MHz to 100 MHz. In addition, there are two frame resets which allow different modules to operate in separate television standards, such as PAL and NTSC.

The TG 2000 Signal Generation Platform can generate different standards, such as PAL and NTSC, at the same time, using the 27 MHz or the two adjustable clocks and the two frame reset pulses. The clocks and frame reset pulses ensure that all modules driving the same format remain synchronized. The CPU configures the clock to generate the clock frequencies and frame reset pulses needed to support the different video formats.

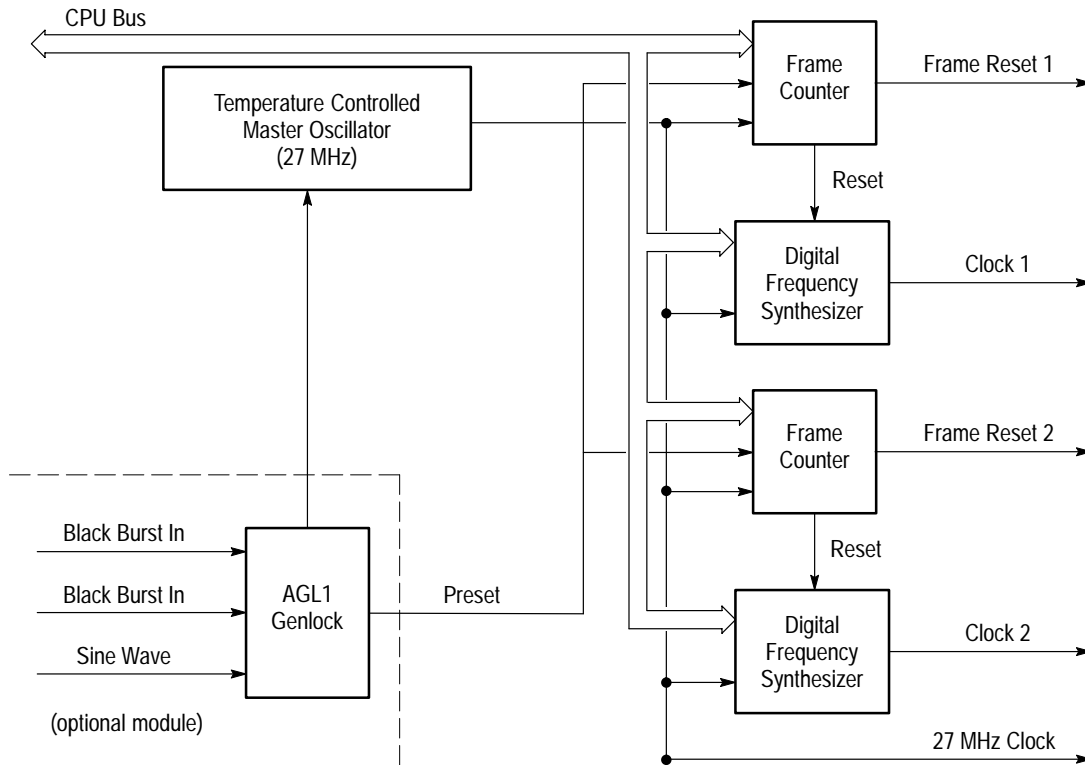

Figure 3-2: Block diagram of the clocks and frame reset signals

External Reference Genlock

An external reference may be used by the optional AGL1 module to lock on one of several video standards. All modules using the same standard as the AGL1 Genlock module are locked to the external reference. Refer to the AGL1 Genlock module user manual for a list of the supported formats.

Module Timing Delay

Most generator modules can be separately timed with respect to the system. This is accomplished by applying a precise, variable delay to the system clocks and frame resets as they enter the module. For conventional television, the adjustment range is effectively infinite, providing adjustment over a complete color frame.

An adjustable trigger output is available on some modules to synchronize external test equipment to any location in the test pattern.

Timing References

The TG 2000 Signal Generation Platform supports internal or external references and signal delay relative to this reference. Video reference signals synchronize the start of test signals of the same type, such as NTSC or PAL. The AGL1 module is required to use external references.

System delay and module timing delay are available to adjust for different signal path delays in an operating environment. System delay uses the optional AGL1 module to lock the system to an external reference signal. Once the reference is defined, you can add a common delay to all modules that generate the same format as the external reference.

Module timing delay, which is available with some modules, allows the delay of one module from other modules that generate a compatible format. Module timing delay does not require an AGL1 module.

Figure 3–3 shows the effects of the system delay and the individual module delay. Note that the BG1 module is at time zero for intermodule timing because it does not support module delay. In Figure 3–3, the BG1 module and AVG1 output signals are delayed 5 μs by the AGL1 module. The AVG1 module is delayed an additional 15 μs by the AVG1 module system delay timer.

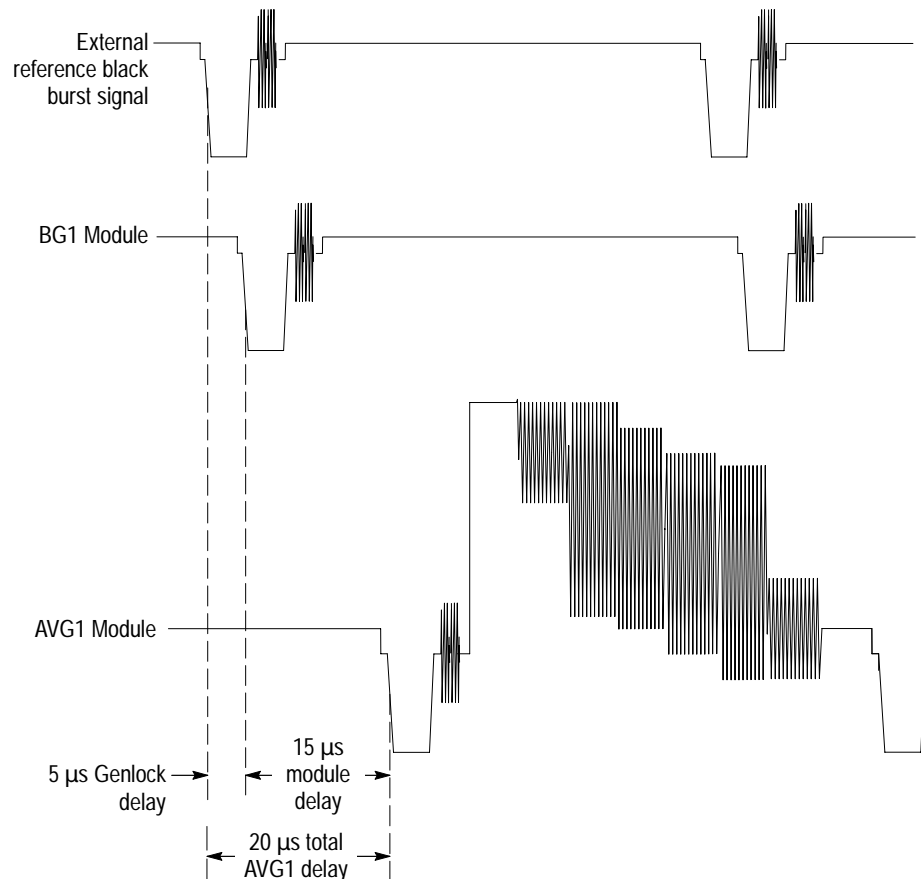

Figure 3–3: Comparison of module delay and system delay from a reference

Timing Delay Block Diagram

Figure 3–4 shows how the module delay is implemented for the generator modules that support it. They have the ability to delay the clock and frame reset pulse for \pm half a frame. The delay is by a number of vertical lines plus a horizontal delay up to the duration of one scan line. The delay is set in the Module Timing window. (The variable system clocks also support module delay.)

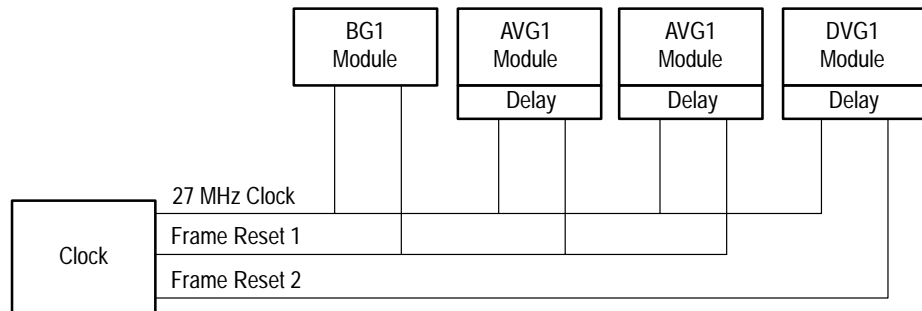

Figure 3–4: Block diagram of module timing delay

System Reference Delay with the AGL1 Module

Figure 3–5 shows how the AGL1 Genlock module can delay its lock signal to effectively delay the clock and frame pulses to all modules. Delaying the clock and frame pulses results in a corresponding delay in the module output. All generator modules using the same standard are affected equally by this delay.

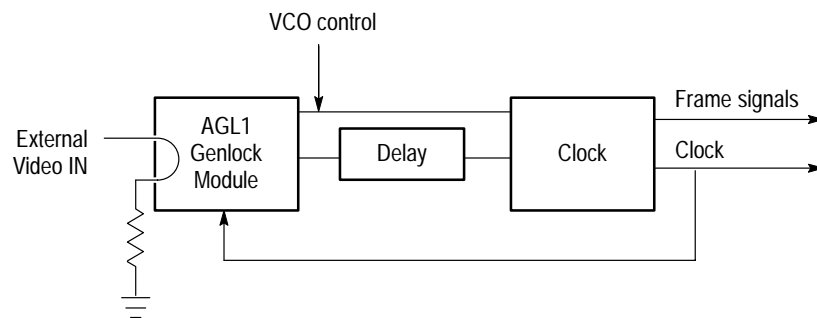

Figure 3–5: Block diagram of the AGL1 Reference timing delay

Performance Verification

Perform the procedures in this section to verify the operation of the TG 2000 Platform mainframe. You do not need to remove the covers from the mainframe.

Verification Interval

To ensure correct instrument operation, perform these procedures once a year. Before performing any procedures, complete all relevant maintenance procedures outlined in the *Maintenance* section of this manual.

Test Equipment Required

Required equipment is shown in Table 4–1. Equipment suggestions are given in the example column. You can substitute other equipment if it meets the requirements in the Minimum specification column. If you do not have the required equipment, you can return your instrument to a Tektronix service center for performance verification.

Table 4–1: Test equipment required for verification

Equipment	Minimum specification	Purpose	Example
Frequency counter	Accuracy and resolution to 8 decimal places, or used with an external reference (WWV, Loran C, or GPS) that will improve the accuracy to 8 decimal places. Frequency 27 MHz.	To check the clock frequency. (This is checked in more detail in the <i>BG1 Black Burst Generator Service Manual</i> .)	Tektronix CDC250 Counter
75 Ω coaxial cable	BNC connectors; 1-meter length	Check clock frequency	012-0074-00
Autotransformer	Voltage range appropriate for the voltage range to be tested	Check input voltage range	Variac – W10MT3W
3.5 inch disk	High density, DOS formatted	Check disk drive operation	
IBM-compatible PC	Able to load and run the SDP2000 Signal Development Program. See its user manual for requirements.	Check the remote interface (parallel and serial)	
SDP2000 Signal Development Program software and user manual	Standard accessory that is shipped with the mainframe	Check the remote interface (parallel and serial)	Four disks, shipped with the SDP2000 manual
Parallel cable	25 pin D-type connector	Check the parallel interface	012-1214-XX
Serial cable	9-pin subminiature D-type connector	Check the serial interface	012-0911-XX

Preparation

1. Install all modules into the mainframe if they are not already installed. Installation instructions appear on page 2–1.
2. Power on the mainframe by setting both the rear-panel POWER switch and front-panel ON/STANDBY switch to on.
3. Allow the mainframe and modules to warm up for at least 20 minutes before performing any tests.

Verification Procedures

Check Input Voltage Range

You can use this procedure to check either the 115 V or 230 V voltage range.

Test Equipment Required: You will need an autotransformer for this test. A waveform monitor is optional (for step 6.).

Procedure: Check Input Voltage Range

1. Set the TG 2000 Platform mainframe rear-panel POWER switch to off.
2. Make sure that the TG 2000 Platform mainframe is set for the voltage that you want to check (115 or 230 V) and that the appropriate fuse is installed. Use the 6 A fuse (159-0342-XX) for 115 V, and the 3 A fuse (159-0005-XX) for 230 V.
3. Connect the mainframe power cord to the autotransformer.
4. Power on the autotransformer and set it for the nominal voltage you want to check (either 115 or 230).
5. Power on the TG 2000 Platform mainframe, both the rear-panel POWER switch and the front-panel ON/Standby switch.
6. Vary the autotransformer from 87 to 132 V or from 174 to 250 V and check that the instrument operates across the voltage range. (For greater confidence, hook up the video outputs to a waveform monitor and check for a stable display of the video signal on the waveform monitor display while varying the voltage to the mainframe.) If the front-panel display disappears, proceed to *Troubleshooting* in Section 6 of this manual.
7. Unplug the mainframe from the autotransformer. Make sure the mainframe power setting and fuse are appropriate for your AC power source, and then plug the mainframe into the AC power source.

Check Fan Operation

The TG 2000 Platform mainframe contains two fans, which should remain in operation while the mainframe is operating.

Procedure: Check Fan Operation

Inspect the mainframe while it is operating to be sure that both fans are operating. You should be able to hear the fans, and to feel vibration on the sides of the mainframe cabinet. If either fan is not operating, proceed to *Troubleshooting* in Section 6 of this manual.

Check CPU Module

Use the following procedures to check the operation of the CPU module.

Test Equipment Required:

- IBM compatible computer
- SDP2000 software and user manual
- Serial cable
- Parallel cable
- Blank disk

Procedure: Check Disk Drive

Create a directory named “test” on the disk as follows:

1. Insert the disk into the mainframe disk drive.
2. Push the **Disk** button to enter the Disk window.
3. Touch **Save Signals to Disk** on the display. See Figure 4–1.



Figure 4–1: Save Signals to Disk window

4. Touch **Select Destination** on the display.
5. Touch **New Dir** on the display.
6. Create a directory named “test” by touching the letters **t e s t** on the display. See Figure 4–2. If you make a mistake, touch **BS** to back space.



Figure 4–2: New Directory window

7. Touch **OK** on the display.
8. Check that the new directory appears in the second column under **Directories** of the Save Signals to Disk window as shown in Figure 4–3. If the directory does not appear, check that your disk is not write protected or try a new formatted disk. Continued failure may indicate a defective disk drive.



Figure 4–3: New directory named Test

Procedure: Check Front-Panel Interface

This procedure checks the front-panel buttons and touch screen operation. It also checks the time and date setting.

1. Check that the **On/Standby** LED is lighted.
2. Check each front-panel button with an LED (except for the On/Standby button) to be sure that the LED lights when you push the button. Follow these special instructions:
 - a. Listen for a ‘beep’ sound each time you push a front-panel button. This indicates that the button is making contact.
 - b. After checking the Enable front-panel button, be sure to leave it in the enabled position (LED on) so that you can continue to use the front-panel interface.
 - c. To check the Edit button LED, push the Modules or List button followed by the Edit button.
 - d. Some of the front-panel buttons remain selected until you select another system function button. For example, to exit the Remote or Modules mode, you must push another front-panel button.
3. Push the **Utilities** button. Push each of the four directional arrow buttons on the front panel and check that the displayed highlight moves accordingly.
4. Use the directional arrows to highlight **Set Date/Time** on the display, and then push the **Select** button.
5. Check that the date and time are correct. If not, select each parameter and adjust it, using the knob or front-panel keyboard.

If this clock does not keep time from power off to power on, refer to *Troubleshooting* in the Maintenance section of this manual.

6. Touch **Load** on the display.
7. Touch **Quit** on the display.
8. Push the **Presets** button.
9. Touch **Presets** on the display.
10. Touch **Create** on the display.
11. Touch **a, b, c, d, e, f, g, and h** on the display. Listen for a ‘beep’ as you touch each character. Touch **BS** to back space over the letters you typed. Repeat with the rest of the alphabet.
12. Touch **Cancel** on the display. Touch **Quit** on the display.

Procedure: Check LCD Contrast

1. Push the **Screen Contrast** button.
2. Turn the knob to vary the screen contrast. Be sure it works smoothly over the adjustment range.
3. Leave the contrast set as desired for best viewing.
4. Push the **Screen Contrast** button again. The LED will go off.

Procedure: Check Serial and Parallel Ports

Use the *SDP2000 Signal Development Program* software to check that the serial and parallel ports are functional.

1. Install the SDP2000 software according to the instructions in the *SDP2000 Signal Development Program User Manual*.
2. Using the 25-pin cable, hook up the TG 2000 Platform mainframe parallel port to a parallel port on your PC.
3. On the TG 2000 Platform mainframe, choose the parallel port as follows:
 - a. Push the **Remote** button.
 - b. Check the **Remote Port** selection at the bottom of the display. If it does not already read **Parallel**, touch it once to toggle the setting to **Parallel**.
4. On the PC, perform the following tasks:
 - a. Open the Tek group (it may already be open from installation) and then double click on the TGCOMM icon to open the communications portion of the SDP2000 program.
 - b. To make the View menu commands available, open a .dnl file as follows:
 - In the File Open dialog box, select the working directory that you specified during SDP2000 installation.
 - Specify .dnl files in the List Files of Type box to display only download files.
 - Open any .dnl file. One example is the file named SDP2000/dvg1/dnls/525-1431.dnl.
 - c. From the Options menu, choose Parallel settings. Select the parallel port you are using (Lpt 1, Lpt 2, or Lpt 3).
 - d. From the View menu, pull down the TG 2000 Signals command and choose Parallel.

5. Check that the TGCOMM displays the list of TG 2000 signal names in the right side of the window. The time it takes for the list to appear will vary based on the speed of the PC. If the list does not appear, check the settings and cable connections, cycle the TG 2000 Platform mainframe power and restart the TGCOMM program. If the TGCOMM still does not display the TG 2000 signal names, it could indicate a problem with the parallel port.
6. Disconnect the parallel cable and connect the serial cable between the TG 2000 Platform mainframe serial port and a serial port on your PC. Be sure that the CTS and RTS lines (pins 7 and 8 on the 9-pin serial connector) are connected.
7. On the TG 2000 Platform mainframe, perform the following tasks:
 - a. Push the **Remote** button.
 - b. Touch **Serial Setup** on the display.
 - c. Note the **Baud Rate**.
 - d. Set the **Flow Control** to **CTS/RTS** and select **Computer** mode.
 - e. Touch the **Remote Port** selection at the bottom of display to toggle the setting to **Serial**.
8. On the PC, perform the following tasks:
 - a. From the Options menu, choose Serial settings. Set the baud rate to match the setting noted on the TG 2000 Platform mainframe and select the serial port that you are using (COM1, COM2, COM3, or COM4).
 - b. From the View menu, pull down the TG 2000 Signals command and choose Serial.
9. Check that the TGCOMM displays the list of TG 2000 signal names in the right side of the window. If the list does not appear, check the settings and cable connections, cycle TG 2000 Platform mainframe power and restart the TGCOMM program. If the TGCOMM still does not display the TG 2000 signal names, it could indicate a problem with the serial port.

Check 27 MHz Clock Frequency

Test Equipment Required:

- Frequency counter
- 75 Ω coaxial cable
- BG1 Generator module installed in the TG 2000 Platform mainframe. If you do not have this module installed, you can use the adjustment procedure on page 5–5 to check the clock frequency.

Procedure: Check 27 MHz Clock Frequency

1. Connect the Clock output and warm up instrument as follows:
 - a. Connect the Clock output from the BG1 Generator module to the frequency counter as shown in Figure 4–4.
 - b. Connect the external reference to the frequency counter if needed (refer to Table 4–1 on page 4–1).
 - c. Make sure that the mainframe and modules have warmed up for at least 20 minutes. If an AGL1 Analog Genlock module is installed, make sure that the TG 2000 Signal Generation Platform is set to internal reference.
2. Set the TG 2000 Platform mainframe as follows:
 - a. Push the **Module** button and touch **BG1** on the display.
 - b. Touch **NTSC** on the display.
 - c. Touch **Black Burst** on the display.
 - d. Touch **Module Parameters** on the display.
 - e. Touch **Clock Out** on the display.
 - f. If the clock frequency is not set to 27.0 MHz, record the frequency setting. You will restore this setting in step 5. Then press **27 μ/M** and **Enter** on the keypad. This sets the output frequency to 27.0 MHz.
 - g. If the selector **Output** at the bottom of the window indicates **Disabled**, touch it once to enable the clock output on the BG1 module.
3. Set the frequency counter for AC coupling, 400 mV amplitude, 75 Ω, and 100 MHz range.

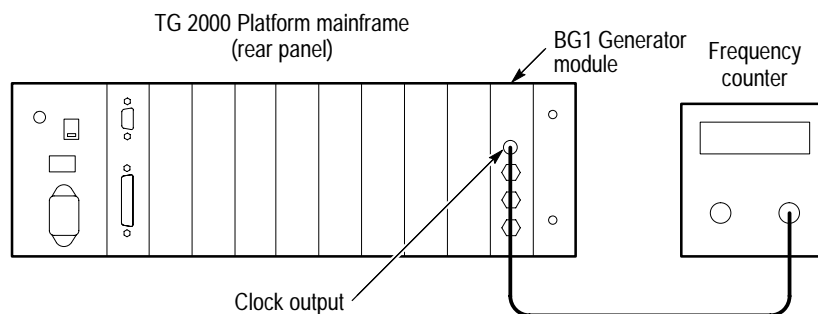

Figure 4–4: Equipment setup for verifying clock operation

4. Check that the clock frequency, as measured on the frequency counter, is 27 MHz \pm 27 Hz (1 ppm). If it is not within this specification, go to the *Adjustments* section and adjust the oscillator.
5. If you changed the clock frequency, restore the clock frequency noted in step 2f.
6. Remove all cables from the mainframe.

This completes the performance verification for TG 2000 Platform mainframe.

Perform the *Performance Verification* procedure for each installed module as described in your module service manuals.

Adjustment Procedures

The procedures in this section should return the TG 2000 Signal Generation Platform to operation within the specifications.

If, after you have performed the following adjustment procedures, the TG 2000 Platform mainframe does not meet or exceed specifications as determined by the performance verification, repair is necessary. Contact your Tektronix Service Center.



WARNING. *Dangerous electric-shock hazards exist inside the system unit. To prevent electrical shock, remove all jewelry before beginning any of the adjustment procedures.*

Equipment Required

Table 5-1: Equipment list for adjustments

Equipment	Specifications	Example or part number
Voltmeter with probes	Accurate to two decimal places	Tektronix DM2510 Digital Multimeter
Frequency counter	Accuracy and resolution to 8 decimal places, or used with an external reference that will improve the accuracy to 8 decimal places. Frequency 27 MHz.	Tektronix CDC250 Counter used with external reference
75 Ω coaxial cable	BNC connectors; 1-meter length	Tektronix Part Number 012-0074-00
75 Ω termination	Precision BNC. Enough to terminate all outputs of installed modules (does not include the BG1 Generator module).	Tektronix Part Number 011-0102-01
75 Ω coaxial cable, SMB-to-BNC	Optional. Used to adjust the oscillator if a BG1 Generator module is not available.	Tektronix Part Number 174-3420-00 (5 inch cable)

Preparation

1. Install all modules into the mainframe if they are not already installed. Do not install the mainframe in a rack. Remove the mainframe from the rack if it is installed in one. Installation instructions appear on page 2–1.
2. Connect the TG 2000 Platform mainframe to the appropriate AC mains power and switch on the rear-panel power switch.
3. Press the On/Standby button on the front panel. At power on, the instrument runs self tests to check all functions of all mainframe components. If the display is working and no errors appear on the display, the mainframe passed its self tests.

The installed modules also run self tests at power on. To determine if they passed their tests, press the **Status** key and check that no module has a “Failed power up” status.

4. Wait 20 minutes for the mainframe and modules to warm up.

Self Calibration

This function performs an auto calibration of the selected modules. Do this before making any adjustments. Self calibration does not require any external test equipment.

NOTE. Allow a 20 minute warm-up period before performing self calibration.

Run the self calibration as follows:

1. Push the **Utilities** button and touch the **Module Self Cal** icon.
2. Ensure that all signal outputs for the modules that you want to calibrate are terminated into 75 Ω . (You do not need to terminate the Trigger outputs of any module and the BG1 module outputs.)
3. If desired, touch all module icons to perform self calibration on the mainframe and all of the installed modules at once. To perform self calibration on the mainframe only, touch the **Clock** module icon.
4. Touch the **Start Cal** icon to begin calibration of the mainframe and any selected modules. Self calibration takes two to five minutes.
5. Check that no errors are displayed during calibration. If errors are displayed, refer to the *Maintenance* section for troubleshooting information.

Adjustment Procedure

NOTE. Perform the preceding Self Calibration procedure before making any adjustments.

There are two areas of adjustment for the mainframe: the +5V supply and the oscillator. Adjusting the +5V Supply is usually only necessary after installing a new Power Supply board.

Adjust +5 V Supply

In this procedure, you will check the various supplies, and then adjust the +5V Supply if necessary.

Test Equipment Required: You will need a voltmeter and probes for this adjustment.

Procedure: Adjust the +5V Supply



WARNING. Dangerous electric shock hazards exist inside the mainframe. Only qualified service personnel should perform these procedures.

1. Check the +5 V, -5 V, +15 V, -15 V, and -2 V supplies as follows:
 - a. At least the Clock and CPU boards must be installed in the mainframe, and it is best to install all modules that will be used. As for all checks, be sure you have allowed 20 minutes warm-up time.
2. Remove the top cover and set it aside.
3. There are four LED indicators on the Power Supply board, visible from the top of the mainframe. Check them as follows:
 - a. Check that the red LED indicators (located on the top of the Power Supply board) are off. The indicators are:
 - DS2 – overtemperature condition
 - DS3 – overvolts condition on the +5 V supply
 - DS4 – overcurrent condition
 - b. Check that the green LED indicator (DS1 on the Power Supply board) is on.
4. Connect the voltmeter leads between ground and the +5V test point, near the top edge of the clock board. See Figure 5-1 for the test point location.
5. Check that the output is 5 volts, ± 50 mV.

- a. If it is within this tolerance, no adjustment is needed. Go to step 7.
 - b. If it is not within this tolerance, go to step 6 and adjust the power supply.
6. Adjust R39 for +5.00 volts on the voltmeter. The adjustment point is along the top edge of the Power Supply board, as seen from the top of the mainframe.
7. Connect the voltmeter leads between ground and each of the following voltage points on the clock board, and check to the indicated tolerances:
 - 5 V test point for $5.1 \text{ V} \pm 5\%$ (-4.9 V to -5.4 V)
 - +15 V $\pm 2\%$ (+14.7 V to +15.3 V)
 - 15 V $\pm 2\%$ (-15.3 V to -14.7 V)
 - 2 V test point for $-2.2 \text{ V} \pm 9\%$ (-2.4 V to -2.0 V)

If any of the voltages are off, it may indicate a problem with the power supply board. Proceed to *Troubleshooting* in the Maintenance section.

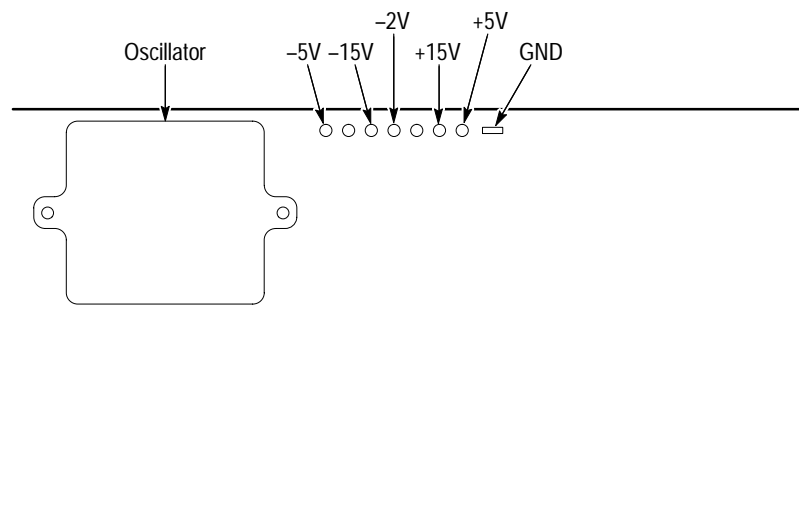

Figure 5-1: Checking the power supply voltages on the clock board

Adjust Oscillator

You only need to adjust the oscillator if you used the *Performance Verification* procedure to check the 27 MHz clock, and it did not meet specifications. To adjust the oscillator, you will need the following equipment:

- Frequency counter
- 75 Ω coaxial cable, BNC
- 75 Ω coaxial cable, SMB-to-BNC, needed only if BG1 Generator module is not available

Procedure: Adjust the Oscillator



WARNING. Disconnect the power cord from the rear panel of the mainframe or turn off the rear-panel power rocker switch before removing the cover of the mainframe. Dangerous voltages can be present in the mainframe even when the front-panel power switch is off.

1. Disconnect the power cord from the rear panel of the mainframe or turn off the rear-panel power rocker switch to the mainframe. Remove the top cover from the mainframe and set it aside.
2. Connect Clock output and warm up instrument as follows:

If you have a BG1 Generator module installed, perform parts **a** through **g** of this step, then skip to step 3.

If you do not have a BG1 Generator module, perform parts **j** through **n** of this step, then proceed to step 3.

WITH BG1 Generator module

- a. Connect the Clock output from the BG1 Generator module to the frequency counter as shown in Figure 5–2.

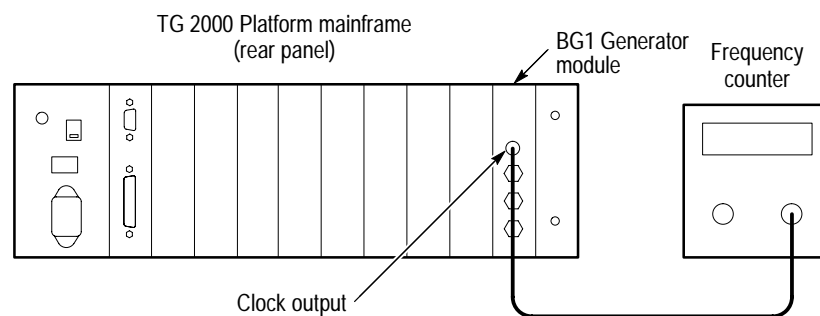

Figure 5–2: Adjusting the oscillator using the BG1 Generator module

- b. Connect the AC power to the rear panel of the mainframe, power on the mainframe, and wait 20 minutes for the mainframe and modules to warm up.
- c. Push the **Module** button and touch **BG1** on the display.
- d. Touch **NTSC** on the display.
- e. Touch **Black Burst** on the display.
- f. Touch **Module Parameters** on the display.
- g. Touch **Clock Out** on the display.
- h. If the frequency is not set to 27.0 MHz, record the frequency setting. (You will restore this setting in step 7.) Then press **2 7 μ /M** and **Enter** on the keypad. This sets the output frequency to 27.0 MHz.
- i. If the selector **Output** at the bottom of the window indicates **Disabled**, touch it once to enable the clock output on the BG1 module.

WITHOUT BG1 Generator module

- j. Make sure that you do not have power applied to the TG 2000 Platform mainframe.
- k. Loosen the rear-panel screws at the bottom of slots 1 and 2. Remove the Clock module from slot 1.



CAUTION. Do not allow the connectors on the coaxial cable to touch any components on the inside of the instrument.

- l. Connect the SMB-BNC cable to J109 on the Clock module. See Figure 5–3 for the location of J109. Connect the BNC end of the cable to a 75 Ω coaxial cable, and then connect the other end of the 75 Ω cable to the frequency counter input.
 - m. Reinstall the Clock module into the mainframe and install the screws that were removed in step k.
 - n. Be sure that the BNC connectors do not touch any components. Connect the AC power to the rear panel of the mainframe, power on the mainframe, and wait 20 minutes for the mainframe and modules to warm up.
3. If an AGL1 Analog Genlock module is installed, make sure that the TG 2000 Signal Generation Platform is set to internal reference.

4. Make sure that the DS100 LED is off. The location of this red LED is shown in Figure 5–3.

(The LED lights when the TG 2000 Platform mainframe is powered on, and remains lighted until the oscillator is sufficiently warmed up to perform this adjustment.)

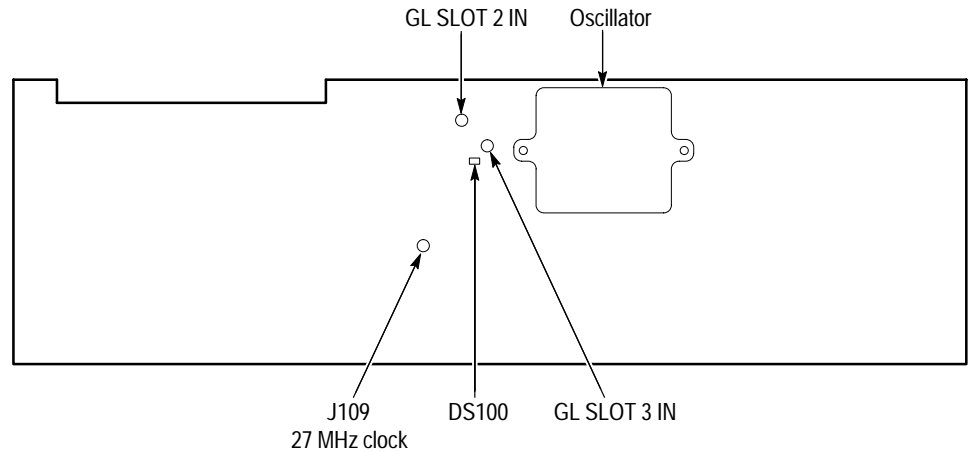

Figure 5–3: Locating parts on the clock board

5. Set the frequency counter for AC coupling, 400 mV amplitude, 75 Ω , and 100 MHz range. Connect the external reference, if needed (refer to page 5–1).
6. Adjust the oscillator through the hole in the top of its case. Adjust for 27.000000 Mhz \pm 1Hz, as read on the frequency counter. The specified accuracy is 1 ppm per year (\pm 27 Hz). Failure to meet specification may indicate a problem with the clock circuit. Proceed to *Troubleshooting* in the Maintenance section.
7. If you used a BG1 Generator module, and you changed the clock frequency, restore the clock frequency noted in step 2h.
8. Disconnect all cables, replace the mainframe cover, and install and tighten the screws.

This completes the adjustment procedure.

Maintenance

This section contains instructions and procedures for maintaining the TG 2000 Platform mainframe. Refer to the service manuals for the individual generator modules for specific instructions on servicing those modules.

The following information can be found in this section:

- Preparation page 6–1
- Inspection and cleaning page 6–3
- After repair adjustments page 6–4
- Repackaging instructions page 6–4
- Removal and replacement procedures page 6–9
- Troubleshooting procedures page 6–37

If the instrument does not function properly, troubleshooting and corrective measures should be taken immediately to prevent additional problems.

NOTE. Contact your local Tektronix representative for information on where to return your instrument if it requires repair during the warranty period.

Preparation

Please read and follow these preparation instructions before attempting to perform any maintenance or service to the instrument.

Servicing Prerequisites

Make sure of the following before beginning any instrument service:

- The maintenance or service of this instrument must be performed by qualified service personnel only.
- Read the *Service Safety Summary* located at the beginning of this manual before attempting to perform any maintenance or service to the instrument.
- Read the *Operating Information* section of this manual before attempting to perform any maintenance or service to the instrument.

Electrostatic Damage Prevention

This instrument contains electrical components that are susceptible to damage from electrostatic discharge. Static voltages of 1 kV to 30 kV are common in unprotected environments.



CAUTION. *Static discharge can damage any semiconductor component in this instrument.*

Observe the following precautions to avoid static damage:

- Minimize handling of static-sensitive components.
- Transport and store static-sensitive components or assemblies in their original containers, on a metal rail, or on conductive foam. Label any package that contains static-sensitive assemblies or components.
- Discharge the static voltage from your body by wearing a wrist strap while handling these components. Servicing static-sensitive assemblies or components should only be performed at a static-free workstation by qualified personnel.
- Nothing capable of generating or holding a static charge should be allowed on the workstation surface.
- Keep the component leads shorted together whenever possible.
- Pick up components by the body, never by the leads.
- Do not slide the components over any surface.
- Avoid handling components in areas that have a floor or work surface covering capable of generating a static charge.
- Use a soldering iron that is connected to earth ground.
- Use only special antistatic, suction-type or wick-type desoldering tools.

NOTE. *A 2% RMA flux content solder is recommended for making repairs in this instrument. Cleaning of rosin residue is not recommended. Most cleaning solvents tend to reactivate the rosin and spread it under components where it may cause corrosion under humid conditions. The rosin residue, if left alone, does not exhibit these corrosive properties.*

Inspection and Cleaning

Preventive maintenance consists of cleaning, visual inspection, performance checking, and, if needed, readjustment. The preventive maintenance schedule established for the instrument should be based on the environment in which it is operated and the amount of use. Under average conditions, scheduled preventive maintenance should be performed every 2000 hours of operation.

General Care

Protect this instrument from adverse weather conditions. The instrument is not waterproof.

Do not expose the LCD display to direct sunlight for long periods of time.



CAUTION. To avoid damage to this instrument, do not expose it to sprays, liquids, or solvents.

To avoid damage to a module circuit board, do not flex the circuit board if you remove the board from its mounting shield. The circuit board can be damaged by flexing. The shield provides necessary structural support to the circuit board.

Cleaning

Clean the instrument often enough to prevent dust or dirt from accumulating. Dirt acts as a thermal insulating blanket that prevents effective heat dissipation, and can provide high-resistance electrical leakage paths between conductors or components in a humid environment.



CAUTION. To avoid damage to the surface of this instrument, do not use abrasive or chemical cleaning agents.

Remove dust from the exterior of the instrument with a lint-free cloth. Use care to avoid scratching the touch screen. Use a small, soft-bristled brush to remove dust from around the selector buttons and connectors. For further cleaning, use a soft cloth or paper towel dampened with water or a 75% isopropyl alcohol solution. If you must clean the interior of the instrument, allow the interior to thoroughly dry before reassembling and applying power to the instrument.

Visual Inspection

After cleaning, carefully check the instrument for defective connections, damaged parts, and improperly seated transistors or integrated circuits. If heat-damaged parts are discovered, determine the cause of overheating before replacing the damaged part.

Periodic checks of the transistors and integrated circuits are not recommended. The best measure of performance is the actual operation of the component in the circuit.

Performance Verification and Readjustments

Check instrument performance after each 2000 hours of operation or every 12 months. This will help to ensure maximum performance and assist in locating defects that may not be apparent during regular operation. Performance verification and adjustment procedures are included in this manual.

After Repair Adjustments

It is recommended that you perform the adjustment procedures for the Power Supply module whenever you have replaced that module. Refer to the *Adjustment Procedures* section of this manual for instructions. The other mainframe modules do not have adjustments.

Repackaging Instructions

Use the following instructions to prepare your instrument for shipment to a Tektronix, Inc., Service Center:

- 1.** Attach a tag to the instrument showing: the owner, complete address and phone number of someone at your firm who can be contacted, the instrument serial number, and a description of the required service.
- 2.** Package the instrument in the original packaging materials. Figures 6–1, 6–2, and 6–3 illustrate how to repack the modules and instrument in their original packaging materials. If the original packaging materials are not available, follow these directions:
 - a.** Obtain a carton of corrugated cardboard having inside dimensions six or more inches greater than the dimensions of the instrument. Use a shipping carton that has a test strength of at least 250 pounds (113.5 kg).
 - b.** Place the instrument in its carrying pouch or surround the instrument with a protective bag.
 - c.** Pack dunnage or urethane foam between the instrument and the carton. If using Styrofoam kernels, overfill the box and compress the kernels by closing the lid. There should be three inches of tightly packed cushioning on all sides of the instrument.
- 3.** Seal the carton with shipping tape, industrial stapler, or both.

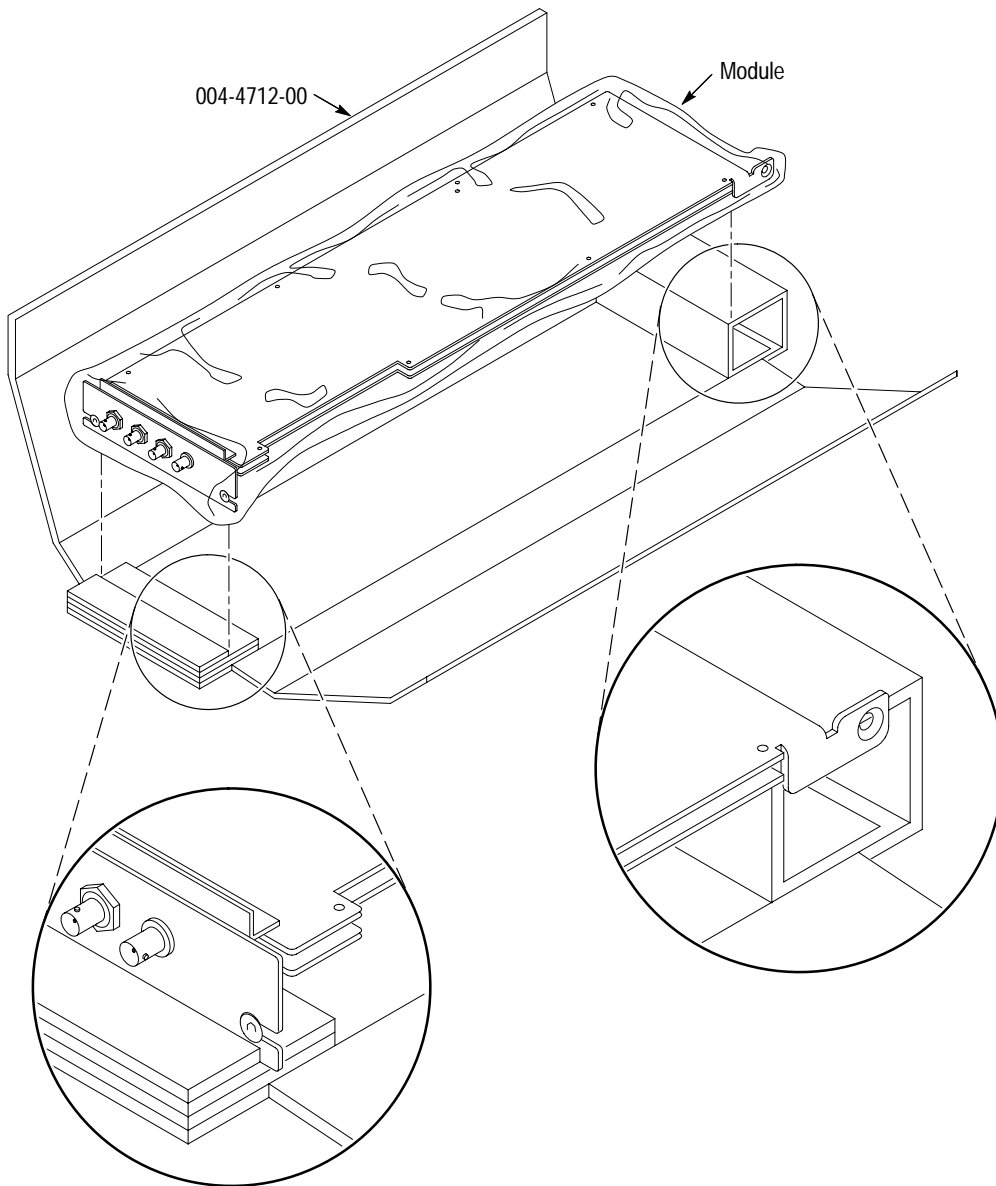

Figure 6-1: Placing the module in the protective wrapping

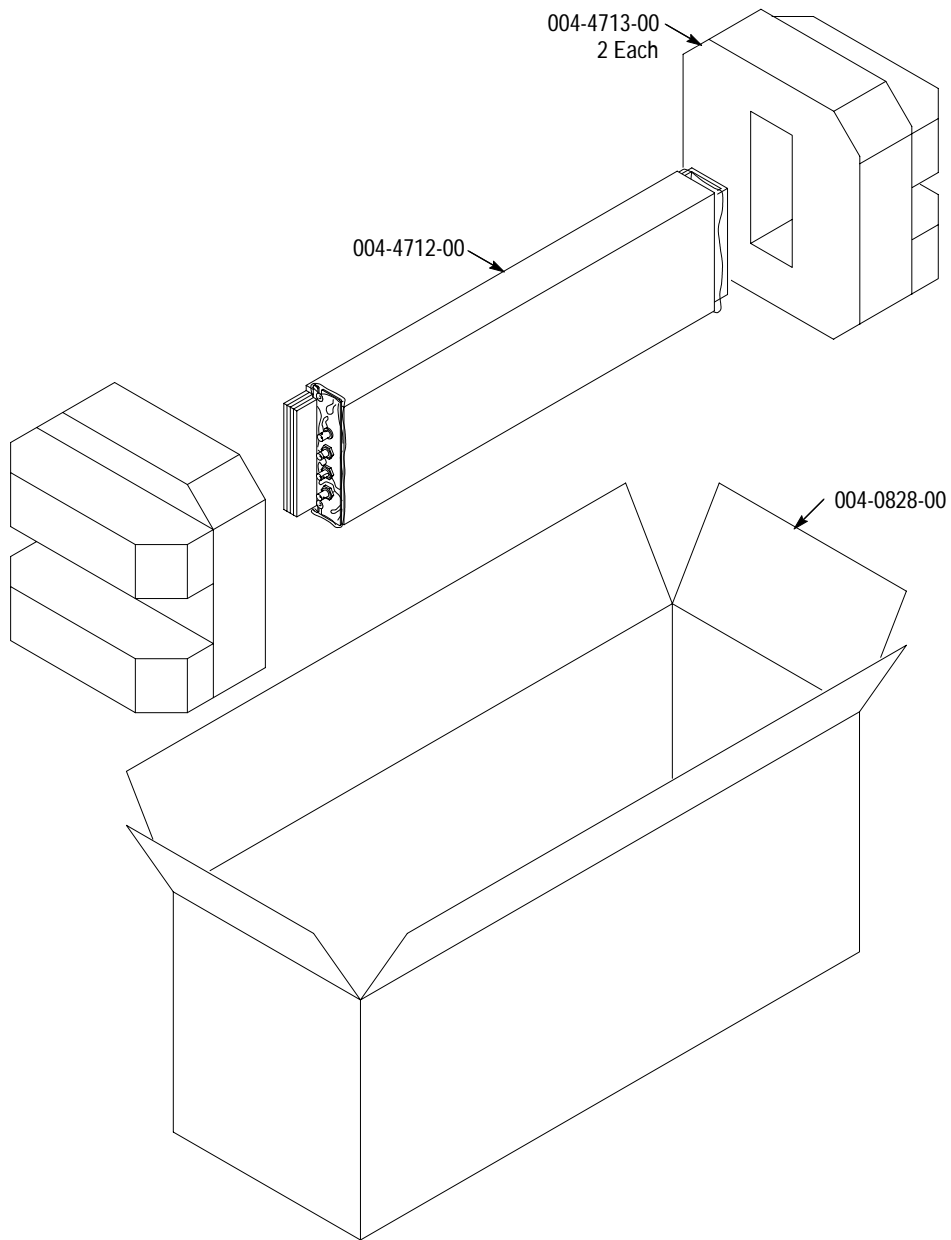

Figure 6-2: Placing the module in the shipping carton

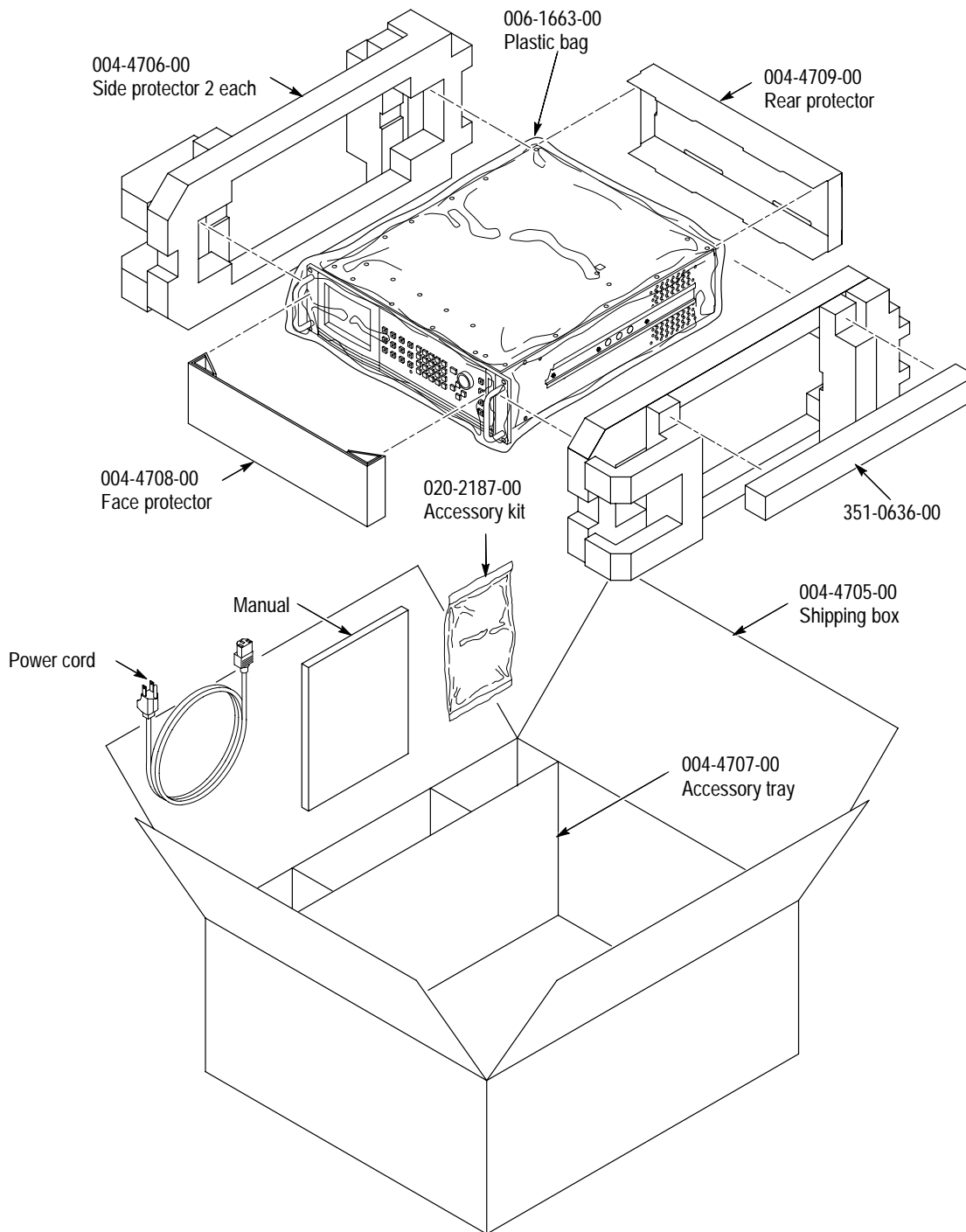

Figure 6-3: Placing the TG 2000 Platform mainframe in the shipping carton

Removal and Replacement

This section contains the instructions on how you can remove and replace the customer replaceable modules and parts of the TG 2000 Signal Generation Platform.

Tools Required

Use the tools in Table 6–1 to disassemble the instrument to its individual modules. Some of these tools are required only for removal of specific instrument components.

Table 6–1: Tools required for module removal

Name	Description
Torx screwdriver handle	Accepts Torx-driver bits
T-10 and T-20 Torx tips	Torx-driver bit for T-10 and T-20 screw heads
#1 point Philips tip	Torx-driver bit for small Philips screw heads
1/2 inch hexagonal driver	Deep socket
9/16 inch hexagonal driver	Deep socket
9/16 inch wrench	
1/4 inch hexagonal driver	
1/16 inch hexagonal wrench	
Torque wrench	16 inch-pounds
Flat blade screwdriver	
Tweezers or needle-nose pliers	
Cleaners	See <i>Cleaning</i> on page 6–3
Soldering iron	40 W
Solder	2% RMA flux content solder

Procedures

Table 6–2 lists the removal and replacement procedures in this section and their starting page numbers.

Table 6–2: Removal and replacement procedure list

Replaceable part	Page number
Top cover	6–11
Front frame	6–12
Front Panel board and LCD Display module	6–13
Knob encoder	6–15
Airflow regulator	6–16
Floppy drive	6–17
Floppy drive assembly shield	6–20
Power Supply module	6–21
Power Supply board	6–24
Line Filter board	6–25
Fuse holder	6–26
CPU module	6–27
CPU Memory board	6–28
Date/time clock	6–29
Clock module	6–31
Clock board oscillator	6–31
Power supply fan	6–32
Clock module fan	6–33
Backplane board and shield	6–34
Backup battery	6–36

Top Cover Remove the top cover by following the procedure below.

1. Turn off the TG 2000 Platform mainframe by pressing the On/Standby button and setting the rear-panel power switch to off.
2. Remove the power cord.



WARNING. To avoid a shock hazard, always remove the power cord before you remove the top cover. Failure to remove the power cord can result in serious injury or death.

3. Refer to Figure 6–4 and remove or loosen all screws to remove the top cover.

To replace the top cover, install and tighten all of the screws in the previous procedure.

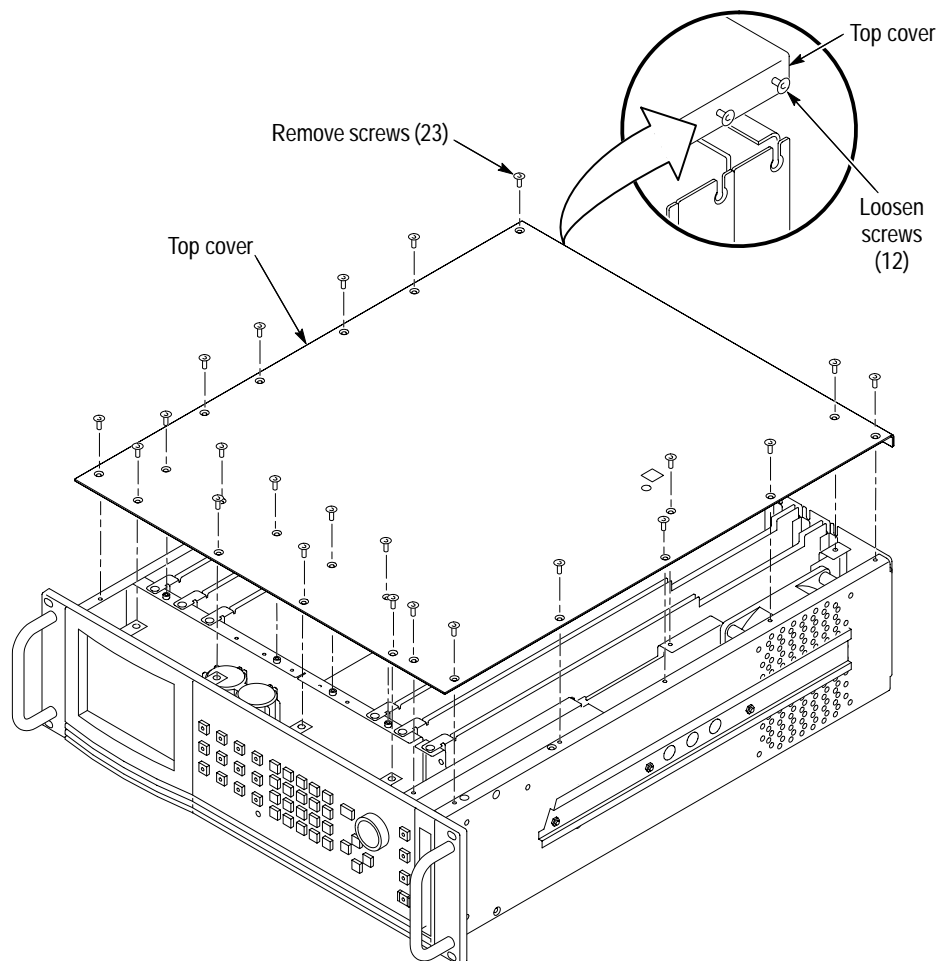

Figure 6–4: Top cover removal

Front-Frame Assembly

The front-frame assembly contains replaceable subparts. Procedures for removing the subparts are included below.

Front Frame. To remove the front-frame assembly, perform the following procedure:

1. Remove the top cover. Refer to *Top Cover* on page 6–11.
2. Disconnect the front-panel ribbon cable from the CPU module and slide the cable out through the slot in the card guide.
3. Remove the four screws from the bottom of the chassis. See Figure 6–5.
4. Remove the four screws from the back of the bow handles.

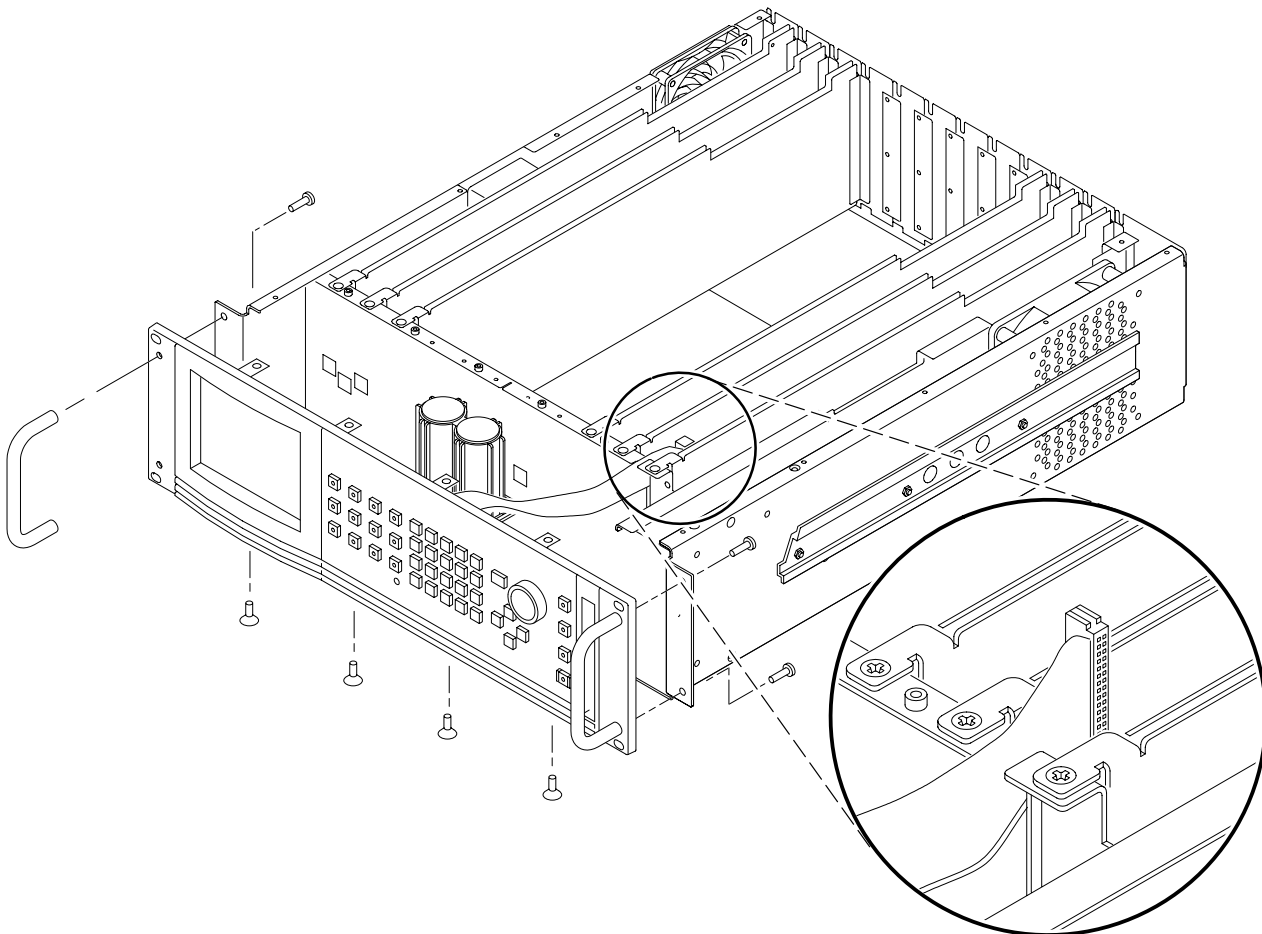

Figure 6–5: Removing the front-frame assembly

To replace the front-frame assembly, perform the following procedure:

1. Place the front-panel ribbon cable through the slot in the card guide.
2. Place the front-frame assembly onto the end of the chassis and install the four T-10 screws through the bottom of the chassis.
3. Install the four T-20 screws through the back of the bow handles and tighten the four screws to 16 inch-pounds (1.81 Newton-meters) using the torque wrench.
4. Connect the front-panel ribbon cable to the connector on the CPU board. See Figure 6-5 for the correct cable orientation.
5. Replace the top cover. Refer to *Top Cover* on page 6-11.

Front Panel Board and LCD Display Module. To remove the Front Panel board and LCD Display module, perform the following procedure:

1. Remove the front-frame assembly. Refer to *Front Frame* on page 6-12.
2. Remove the front-panel knob using the 1/16 inch hexagonal wrench.
3. Place the front-frame assembly face down on a soft surface with both ends of the front frame supported. See Figure 6-6.

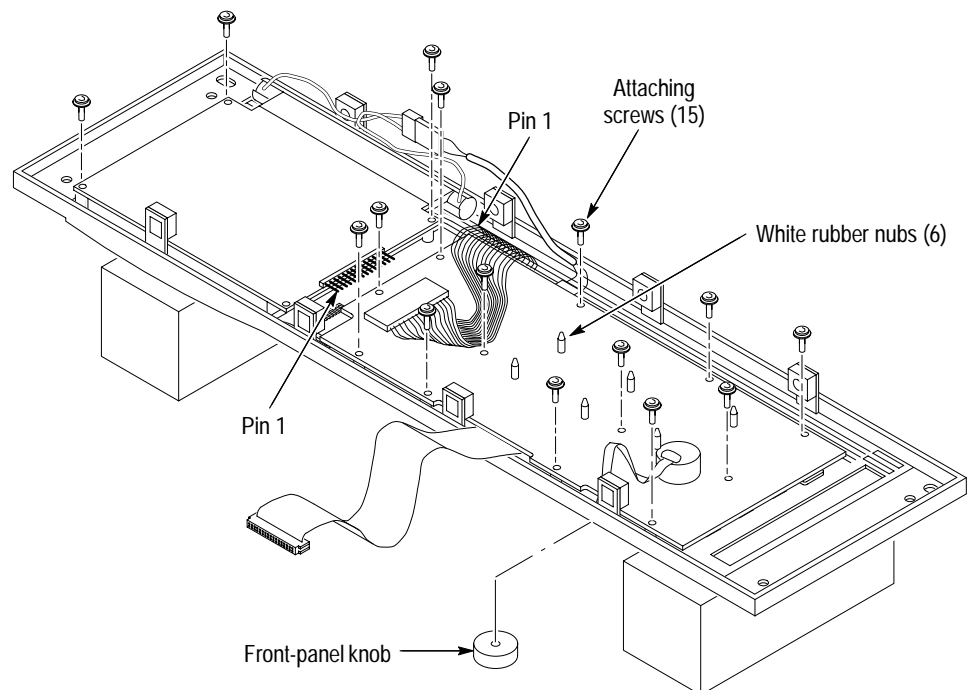

Figure 6-6: Removing the front-panel board and display module

4. Disconnect the 14-pin cable from the LCD Display module.
5. Remove the three screws from the LCD Display module and the twelve screws from the Front Panel board.

NOTE. *The front-panel keypad buttons are seated loosely in the front frame. Lifting the Front Panel board may cause these buttons to come out of their seated positions. Lift the Front Panel board out of the front frame while pushing the six rubber nubs through the circuit board to minimize the disturbance of these buttons.*

6. Lift the Front Panel board and LCD Display module from the front frame.
7. Disconnect the remaining three cables connecting the Front Panel board and the LCD Display module. See Figure 6-7.

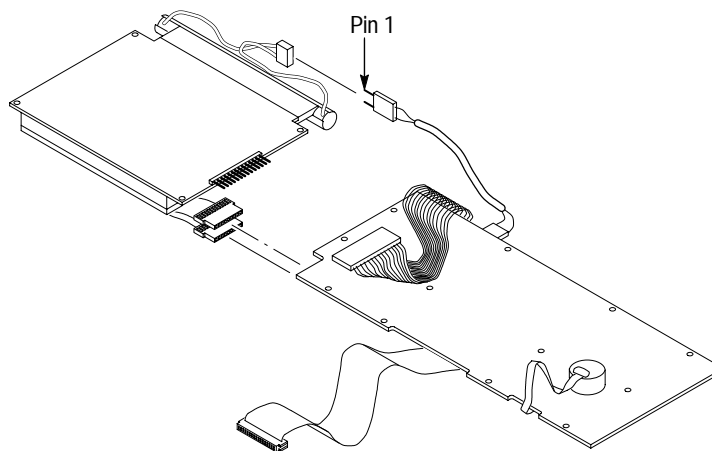

Figure 6-7: Disconnecting the LCD Display module and Front Panel board

To replace the Front Panel board and LCD Display module, perform the following procedure:

1. Install any unseated keypad buttons into the front frame, and then install the isomeric keypad into the keypad buttons.
2. Connect the two blue cables and the two-pin cable connecting the Front Panel board and the LCD Display module.
3. Install the Front Panel board and LCD Display module into the front frame. Make sure that the six rubber nubs from the keypad go through the holes in the Front Panel board. Once the Front Panel is seated in position, pull the rubber nubs through the circuit board.

4. Install the three screws into the LCD Display module and the twelve screws into the Front Panel board.
5. Press the front-panel buttons to check that they operate freely and are not sticking against the front frame. If the buttons are sticking, loosen the twelve Front Panel board screws and adjust the circuit board as necessary. Tighten the twelve screws when you have positioned the circuit board.
6. Connect the 14-pin cable from the Front Panel board to the LCD Display module.
7. Install the front-panel knob using the 1/16 inch hexagonal wrench.
8. Replace the front-frame assembly. Refer to *Front Frame* on page 6–12.

Knob Encoder. To remove the front-panel knob encoder, perform the following procedure:

1. Remove the Front Panel board. Refer to *Front Panel Board and LCD Display Module* on page 6–13.
2. Disconnect the knob-encoder cable from the Front Panel board.
3. Remove the knob encoder retaining nut using the 1/2-inch hexagonal driver.
4. Slide the knob encoder through the back of the Front Panel board.

To replace the front-panel knob encoder, perform the following procedure:

1. Align and install the knob-encoder spacer on the knob encoder. See Figure 6–8.

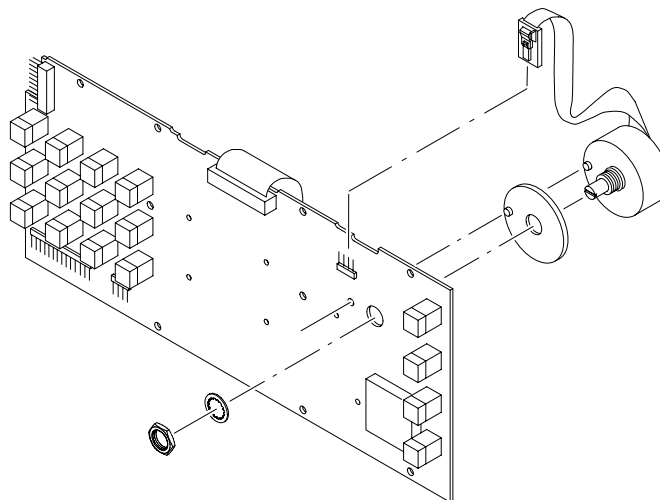

Figure 6–8: Replacing the knob encoder

2. Slide the shaft of the knob encoder through the back of the Front Panel board.
3. Align the knob encoder and install the retaining nut.
4. Connect the knob-encoder cable to the Front Panel board.

Airflow Regulator. To remove the airflow regulator, perform the following procedure:

1. Remove the front-frame assembly. Refer to *Front Frame* on page 6–12.
2. Remove the airflow regulator from the chassis.

To replace the airflow regulator, perform the following procedure:

1. Install the airflow regulator into the slots in the chassis. See Figure 6–9.
2. Replace the front-frame assembly. Refer to *Front Frame* on page 6–12.

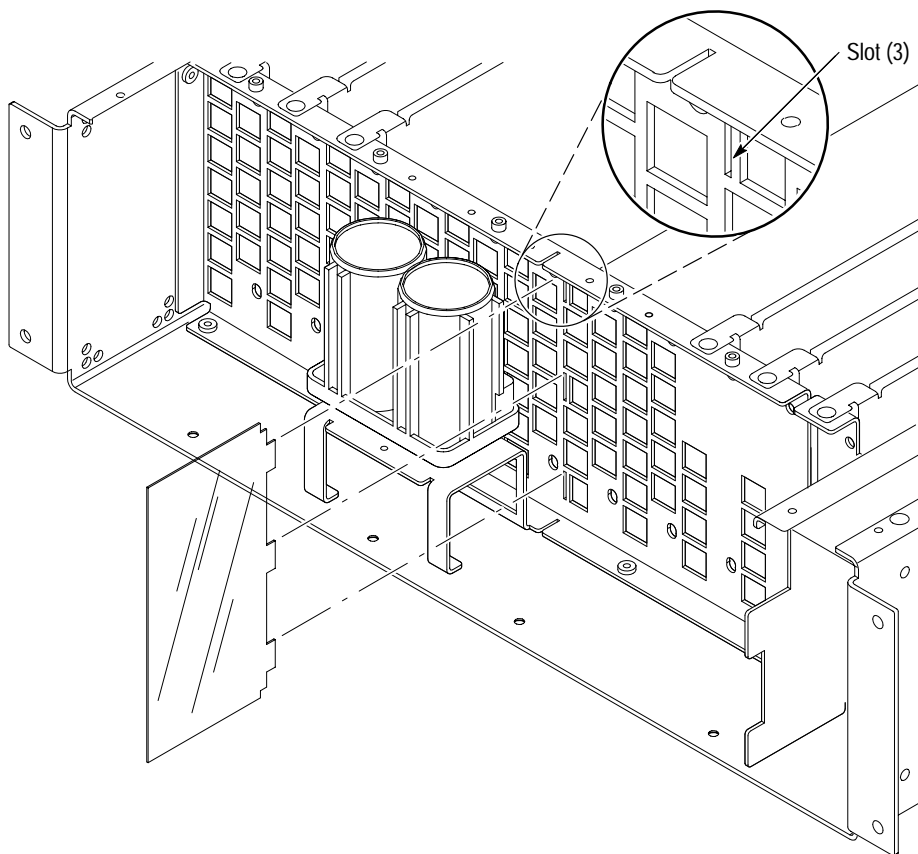

Figure 6–9: Replacing the airflow regulator

Floppy Drive Assembly

The floppy drive assembly contains replaceable subparts. Procedures for removing the subparts are included below.

NOTE. The following procedure is for platforms with serial numbers B011100 and above. For platforms with serial number B011099 or below, contact your Tektronix representative to purchase the Floppy Drive Replacement Kit for the TG 2000 Signal Generation Platform.

Floppy Drive. To remove the floppy drive assembly, follow these steps:

1. Remove the front-frame assembly. Refer to *Front Frame* on page 6–12.
2. Remove the two attaching screws from the side of the chassis. See Figure 6–10.
3. Slide the floppy drive assembly out through the front of the chassis.
4. Remove the three screws from the floppy drive electrical shield (two on the top and one on the bottom). See Figure 6–11. Save the screws.
5. Slide the floppy drive out of the electrical shield.
6. Disconnect the cable from the floppy drive, leaving the other end of the cable connected to the CPU circuit board. See Figure 6–11. Keep the protective sleeve on the cable.

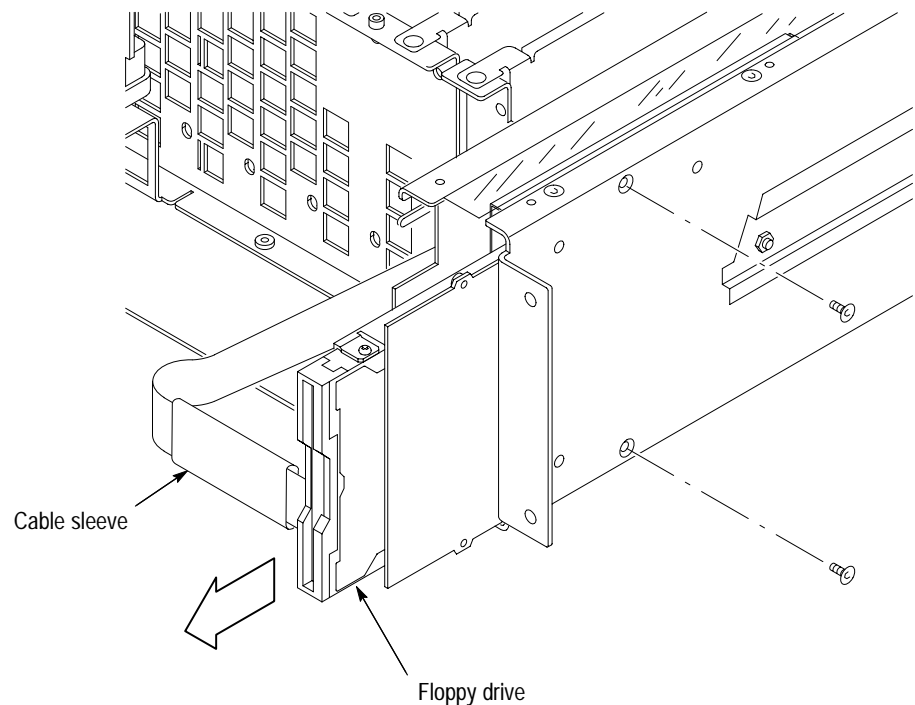

Figure 6–10: Removing the floppy drive

To replace the floppy drive, perform the following procedure:

1. Connect the cable from the CPU module to the new floppy drive.
2. Wrap the cable around the floppy drive and slide the new floppy drive and cable into the new electrical shield. Make sure the cable sleeve is in position as shown in Figure 6–11. Dress the excess cable toward the front of the floppy drive, and not next to the CPU circuit board.
3. Install the three attaching screws through the electrical shield and into the floppy drive, tightening the top two screws first and the bottom screw last.
4. Slide the floppy drive assembly into the chassis.
5. Install the two attaching screws into the side of the chassis.
6. Replace the front-frame assembly. Refer to *Front Frame* on page 6–12.

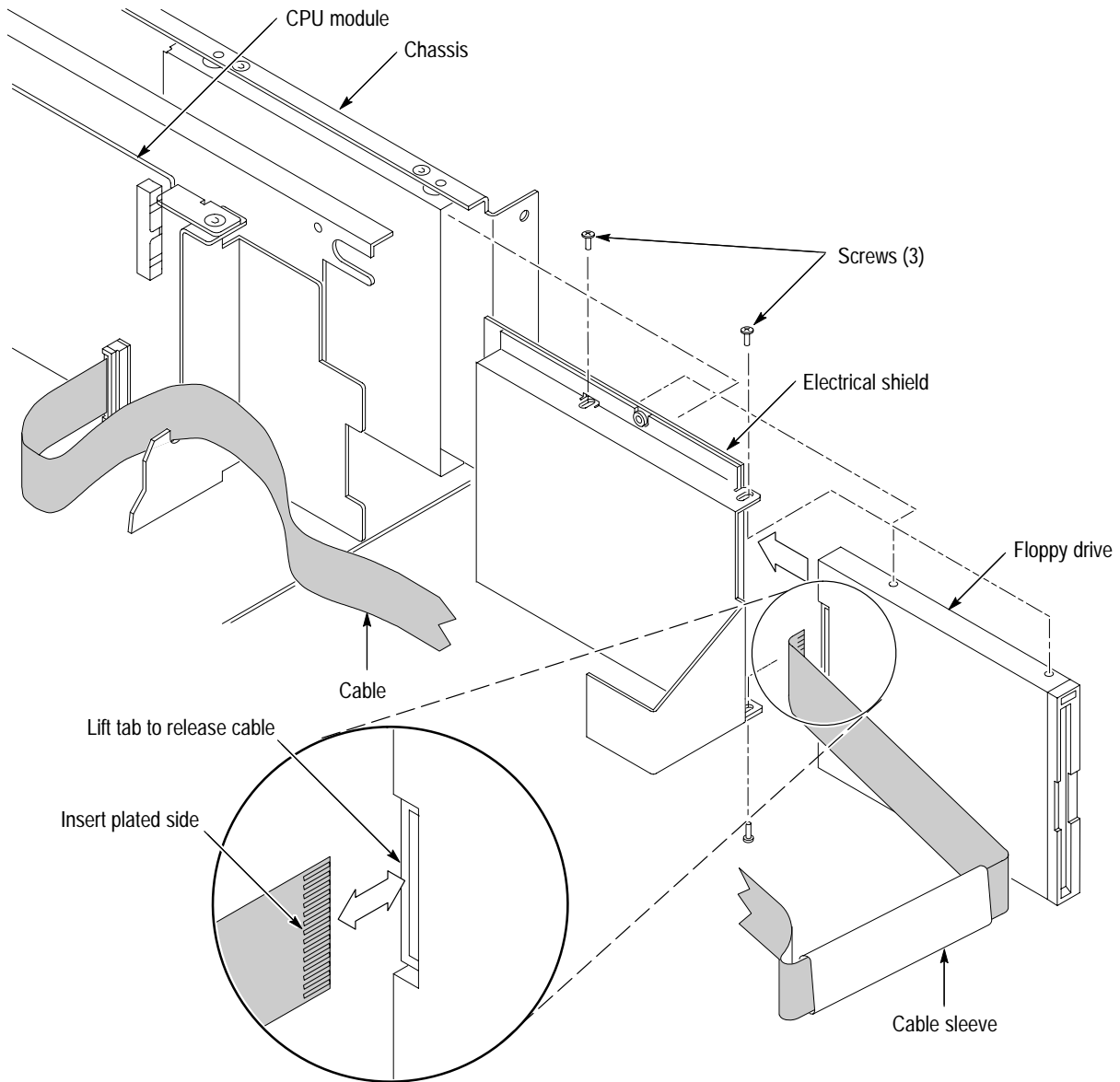

Figure 6-11: Installing the floppy drive into the chassis

Floppy-Drive Assembly Shield. The floppy drive assembly shield (Figure 10–3-2) is an outer shield that encases the floppy disk drive and the electrical shield. To remove the floppy drive assembly shield, perform the following procedure:

1. Remove the floppy drive assembly (floppy drive and electrical shield). Refer to *Floppy Drive* on page 6–17.
2. Remove the Power Supply module. Refer to *Power Supply Module* on page 6–21.
3. Remove the rackmount hardware from the floppy drive side of the chassis.
4. Remove the six attaching screws from the chassis. See Figure 6–12.

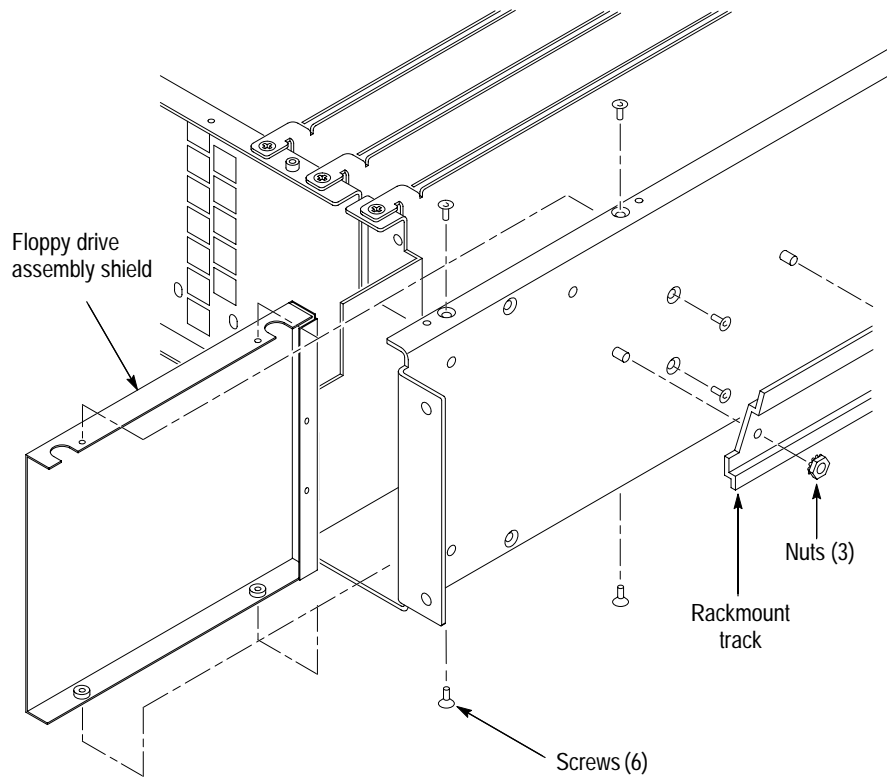

Figure 6–12: Removing the floppy drive assembly shield

5. Slide the floppy drive assembly shield out through the front of the chassis.

To replace the floppy drive assembly shield, perform the following procedure:

1. Slide the floppy drive assembly shield in through the front of the chassis.
2. Install the six attaching screws into the chassis.
3. Install the rackmount hardware onto the side of the chassis.
4. Install the Power Supply module. Refer to *Power Supply Module* on page 6–21.
5. Install the floppy drive. Refer to *Floppy Drive* on page 6–17.

Power Supply Module Assembly

The Power Supply module assembly contains replaceable subparts. Procedures for removing the subparts are included below.

NOTE. Before replacing the Power Supply module, check the serial number of the instrument chassis (located on the right side of the chassis). Instruments with serial number B010391 and below require a wire-strap kit (Tektronix part number 040–1522–XX) installed on the Power Supply module. See Figure 6–13. Install the wire-strap kit at this time if it is required for your instrument and has not already been installed.

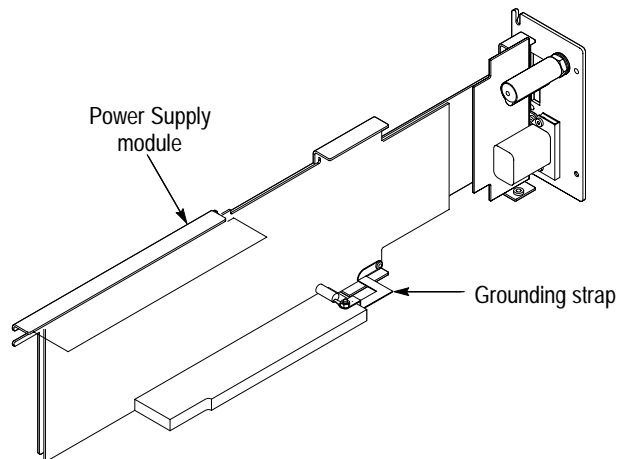

Figure 6–13: Location of the Power Supply module grounding strap (SN B010391 and below only)

Power Supply Module. To remove the Power Supply module, perform the following procedure:

1. Remove the top cover. Refer to *Top Cover* on page 6–11.

2. Disconnect the fan cable from the Power Supply module, the ribbon cable from the CPU module, and the two cables from the Backplane board. See Figure 6–14.

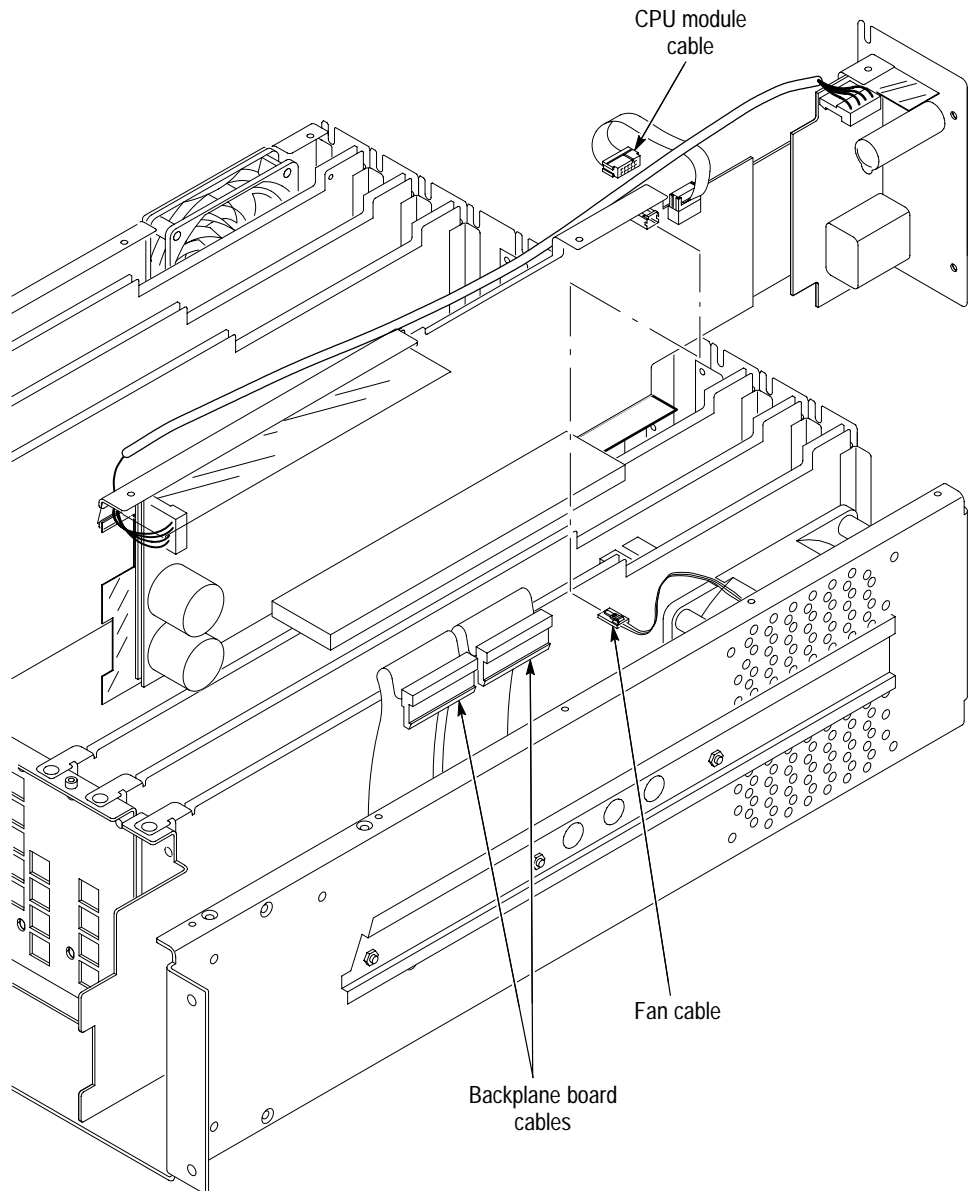

Figure 6–14: Removing the Power Supply module

3. Remove the six attaching screws from the bottom of the chassis and loosen the lower attaching screw on the rear panel of the Power Supply module. See Figure 6–15.
4. Lift the Power Supply module from the TG 2000 Platform mainframe.

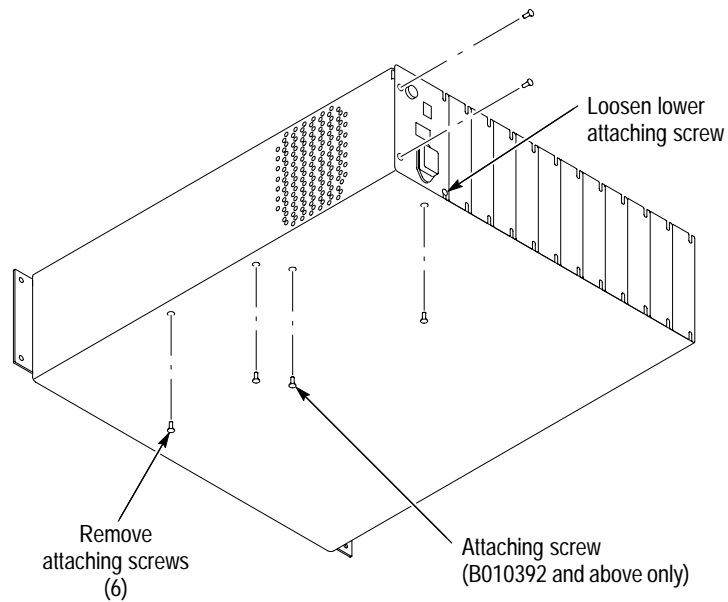

Figure 6–15: Removing the Power Supply module attaching screws

To replace the Power Supply module, perform the following procedure:

1. Make sure that the two cables connecting the Backplane board and the Power Supply module are firmly seated on the Backplane board connectors.
2. Slide the Power Supply module into the TG 2000 Platform mainframe.
3. Install the six attaching screws into the Power Supply module and tighten the lower screw on the rear panel of the Power Supply module.
4. Connect the fan cable to the Power Supply module, the ribbon cable from the CPU module, and the two cables from the Backplane board. See Figure 6–14.
5. Replace the top cover. Refer to *Top Cover* on page 6–11.

Power Supply Board. To remove the Power Supply board, follow these steps:

NOTE. If you return the Power Supply board to Tektronix for module exchange, do not return any of the four attaching cables. The cables will not be included in the exchange module that you will receive back from Tektronix.

1. Remove the Power Supply module. Refer to *Power Supply Module* on page 6–21.
2. Disconnect the cable from the Power Supply board that attaches to the Line Filter board.
3. Remove the eight attaching screws from the Power Supply board. See Figure 6–16.

To replace the Power Supply board, follow these steps:

1. Install the eight attaching screws into the Power Supply board.
2. Connect the cable from the Line Filter board to the Power Supply board.
3. Install the Power Supply module. Refer to *Power Supply Module* on page 6–21.

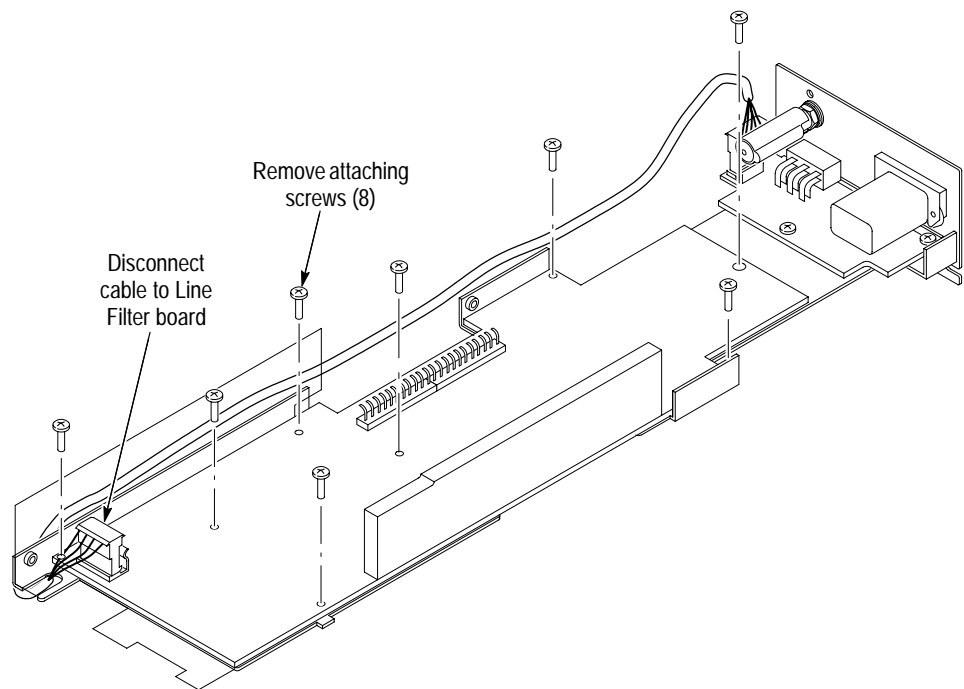

Figure 6–16: Removing the Power Supply board

Line Filter Board. To remove the Line Filter board, perform the following procedure:

1. Remove the Power Supply module. Refer to *Power Supply Module* on page 6–21.
2. Disconnect the cables from the Line Filter board that attach to the Power Supply board and the rear-panel fuse holder.
3. Disconnect the two cables from the switch on the power-supply rear panel.
4. Remove the two attaching screws from the rear-panel AC power connector.
5. Remove the three attaching screws from the Line Filter board.

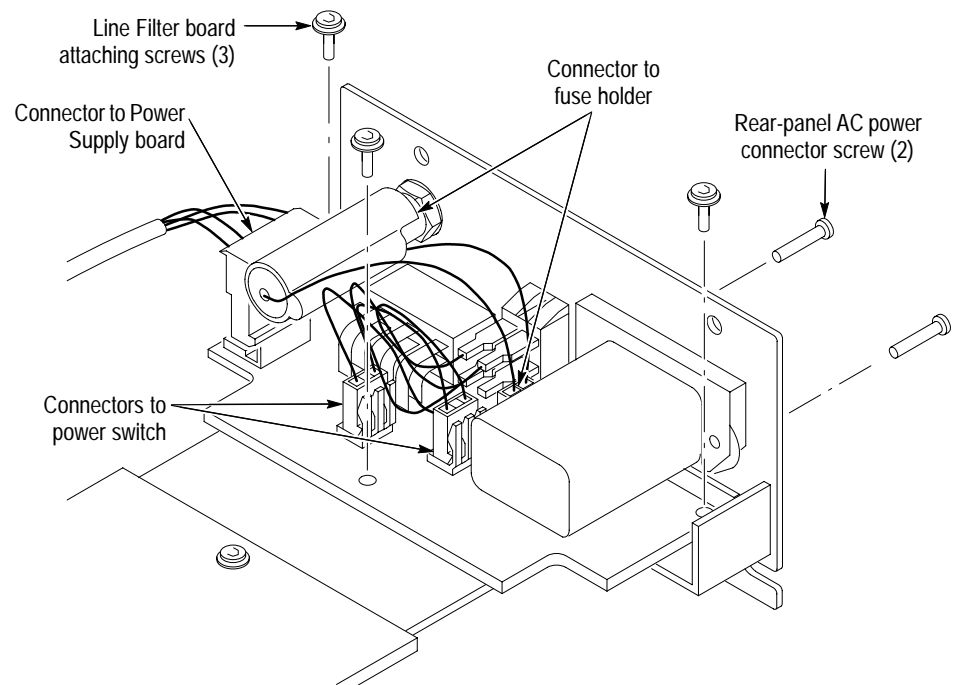

Figure 6–17: Removing the Line Filter board

To replace the Line Filter board, perform the following procedure:

1. Install the three attaching screws into the Line Filter board.
2. Install the two attaching screws into the rear-panel AC power connector.
3. Connect the cables to the Line Filter board that attach to the Power Supply board and the rear-panel fuse holder.

4. Install the Power Supply module. Refer to *Power Supply Module* on page 6–21.

Fuse Holder. To remove the fuse holder, perform the following procedure:

1. Remove the Power Supply module. Refer to *Power Supply Module* on page 6–21.
2. Disconnect the fuse-holder cable from the Line Filter board.
3. Slide the plastic cover off of the fuse holder.
4. Unsolder the two wires from the fuse holder.
5. Remove the attaching nut and washer from the fuse holder using a 9/16-inch wrench.
6. Slide the fuse holder out through the front of the rear panel.

To replace the fuse holder, perform the following procedure:

1. Slide the fuse holder in through the front of the rear panel. See Figure 6–18.
2. Install the attaching nut and washer from the fuse holder using a 9/16-inch wrench.
3. Solder the two wires from the cable on the Line Filter board to the fuse holder. See Figure 6–18.
4. Slide the plastic cover onto the fuse holder.

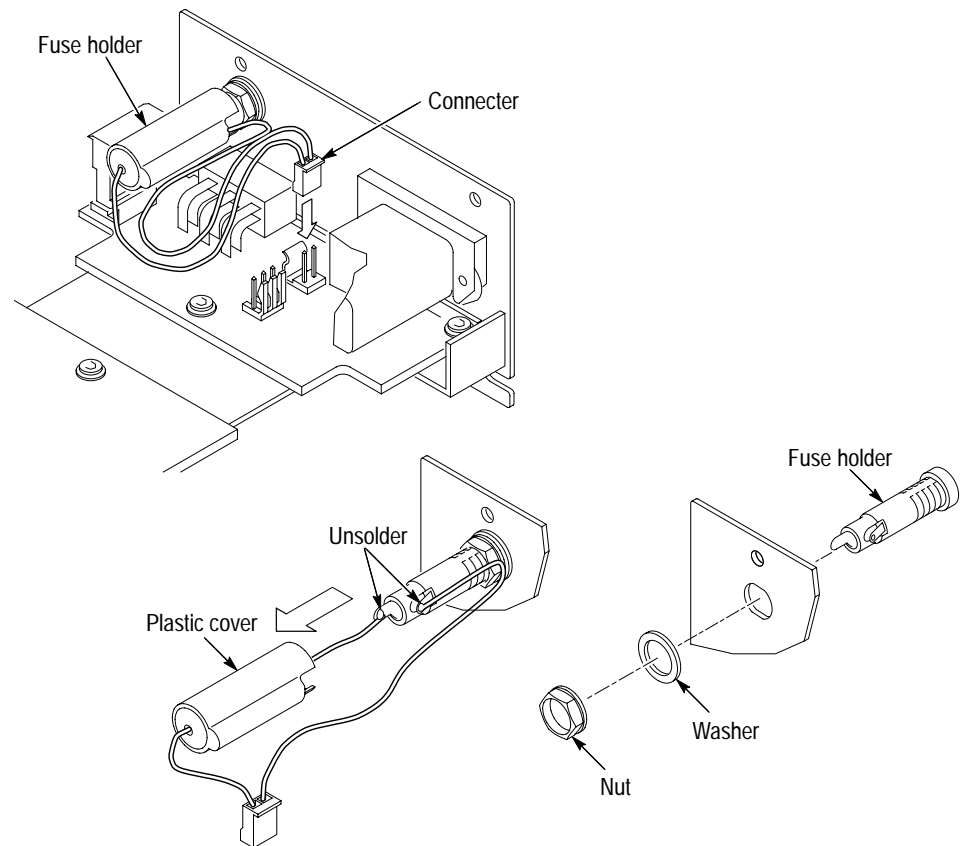

Figure 6-18: Installing the fuse holder

5. Connect the fuse-holder cable to the Line Filter board.
6. Install the Power Supply module. Refer to *Power Supply Module* on page 6-21.

CPU Module Assembly

The CPU module assembly contains replaceable subparts. Procedures for removing the subparts are included below.

CPU Module. To remove the CPU module, perform the following procedure:

1. Remove the top cover. Refer to *Top Cover* on page 6-11.
2. Remove the attaching screw from the front of the CPU module and loosen the lower rear-panel screw of the CPU module.
3. Disconnect the power-supply cable, the front-panel cable, and the GP1 cable if a GP1 module is installed.
4. Lift the CPU module from the mainframe.

5. Disconnect the floppy cable from the CPU module. See Figure 6–19.

To replace the CPU module, perform the following procedure:

1. Connect the floppy cable to the CPU module. See Figure 6–19.
2. Install the CPU module into the mainframe.

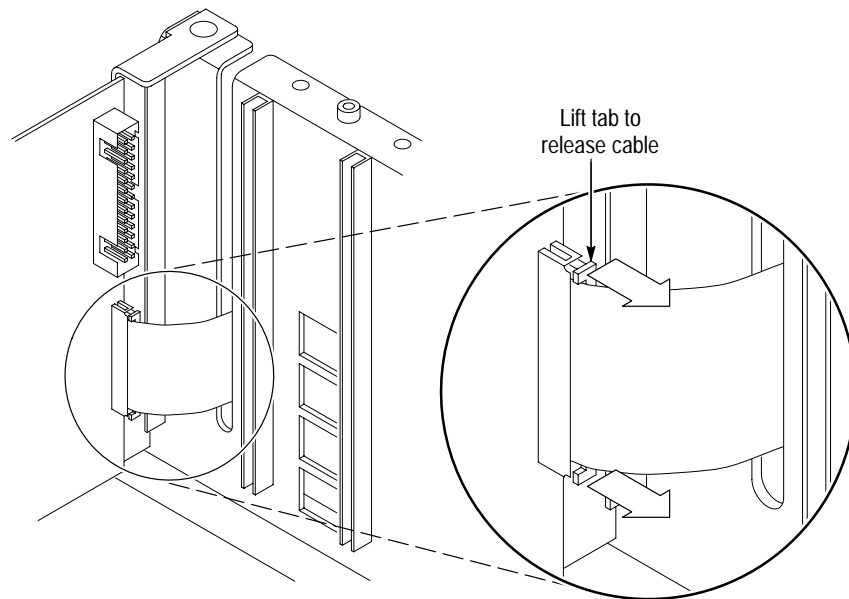

Figure 6–19: Removing the CPU module floppy cable

3. Connect the power-supply cable, the front-panel cable, and the GPI cable if a GPI module is installed.
4. Install the attaching screw into the front of the CPU module and tighten the lower rear-panel screw of the CPU module.
5. Replace the top cover. Refer to *Top Cover* on page 6–11.

CPU Memory Board. To remove the CPU Memory board, perform the following procedure:

1. Remove the CPU module. Refer to *CPU Module* on page 6–27.
2. Remove the memory board from the CPU module. See Figure 6–20.

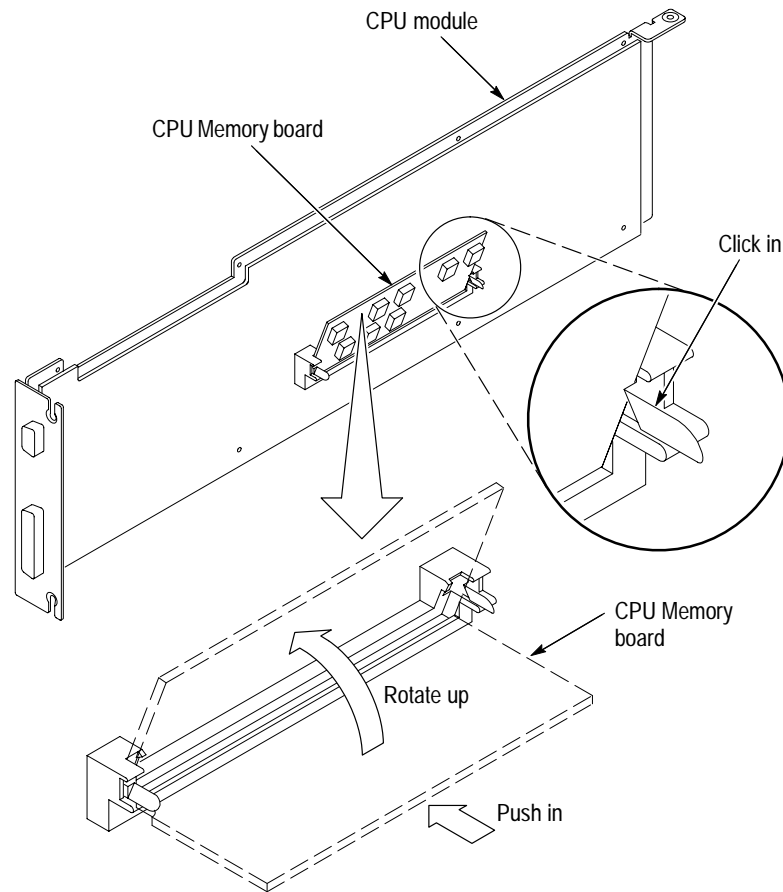

Figure 6–20: Installing the CPU Memory board

To replace the CPU Memory board, perform the following procedure:

1. Install the CPU Memory board into the CPU module. See Figure 6–20.
2. Install the CPU module. Refer to CPU Module on page 6–27.

Date/Time Clock. To remove the date/time clock, perform the following procedure:

1. Remove the CPU module. Refer to *CPU Module* on page 6–27.
2. Remove the date/time IC from the CPU module. See Figure 6–21.

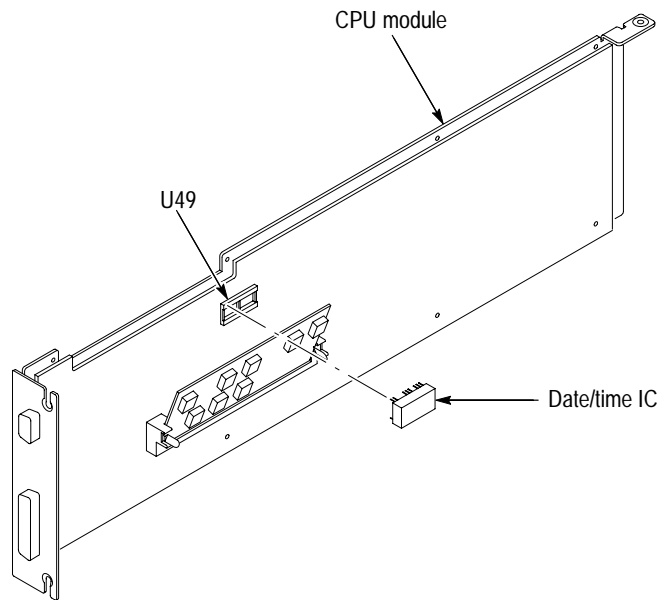

Figure 6-21: Removing the date/time clock from the CPU module

To replace the date/time clock, perform the following procedure:

1. Install the date/time IC into its socket. Check for bent pins.
2. Install the CPU module. Refer to CPU Module on page 6-27.

Clock Module Assembly

The Clock module assembly contains replaceable subparts. Procedures for removing the subparts are included below.

Clock Module. To remove the Clock module, perform the following procedure:

1. Remove the top cover. Refer to *Top Cover* on page 6–11.
2. Remove the attaching screw from the front of the Clock module and loosen the lower rear-panel screw of the Clock module.
3. Disconnect the cable from the AGL1 module if one is installed.
4. Lift the Clock module from the mainframe.

NOTE. *If you return the Clock module to Tektronix for module exchange, do not return any attaching cables. The cables will not be included in the exchange module that you will receive back from Tektronix.*

To replace the Clock module, perform the following procedure:

1. Install the Clock module into the mainframe.
2. Connect the cable from the AGL1 module if one is installed. Refer to the manual for the AGL1 module for installation instructions.
3. Install the attaching screw into the front of the Clock module and tighten the lower rear-panel screw on the Clock module.
4. Install the top cover. Refer to *Top Cover* on page 6–11.

Clock Board Oscillator. To remove the Clock board oscillator, perform the following procedure:

1. Remove the Clock module. Refer to *Clock Module* on page 6–31.
2. Remove the two attaching screws from the oscillator cover.
3. Lift up the oscillator cover.
4. Remove the oscillator from the connector.

To replace the Clock board oscillator, perform the following procedure:

1. Install the oscillator onto the Clock board. See Figure 6–22.
2. Align the oscillator cover and install the two attaching screws.
3. Install the Clock module. Refer to *Clock Module* on page 6–31.

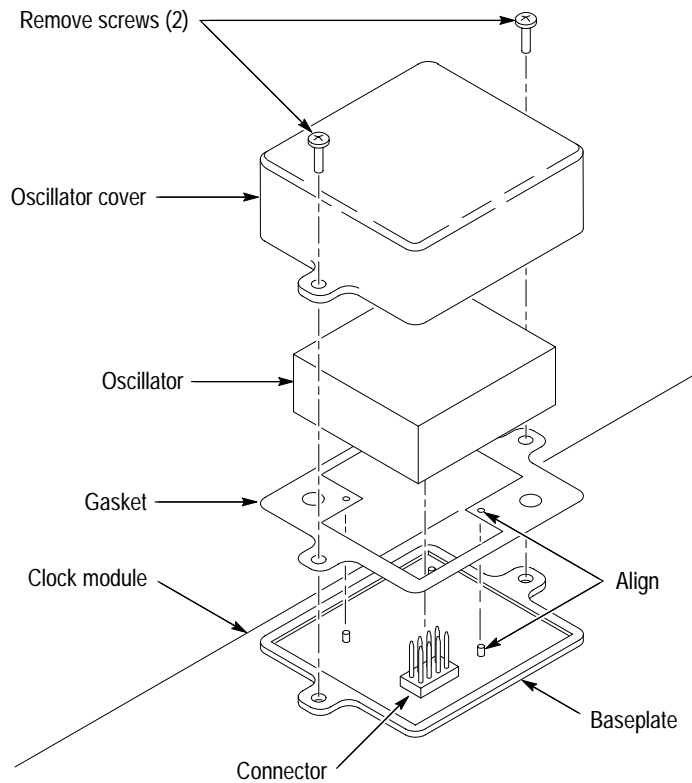

Figure 6–22: Installing the Clock board oscillator

Fans There are two fans in the TG 2000 Platform mainframe. Procedures for removing each fan are included below.

Power Supply Fan. To remove the Power Supply board fan, perform the following procedure:

1. Remove the Power Supply module. Refer to *Power Supply Module* on page 6–21.
2. Remove the four attaching screws from the outside of the chassis and lift the fan from the chassis. See Figure 6–23.

To replace the Power Supply board fan, perform the following procedure:

1. Position the fan so that the air-flow indicator on the fan housing points to the outside of the instrument and so that the fan cable is on the top of the fan.
2. Install the four attaching screws.
3. Install the Power Supply module. Refer to *Power Supply Module* on page 6–21.

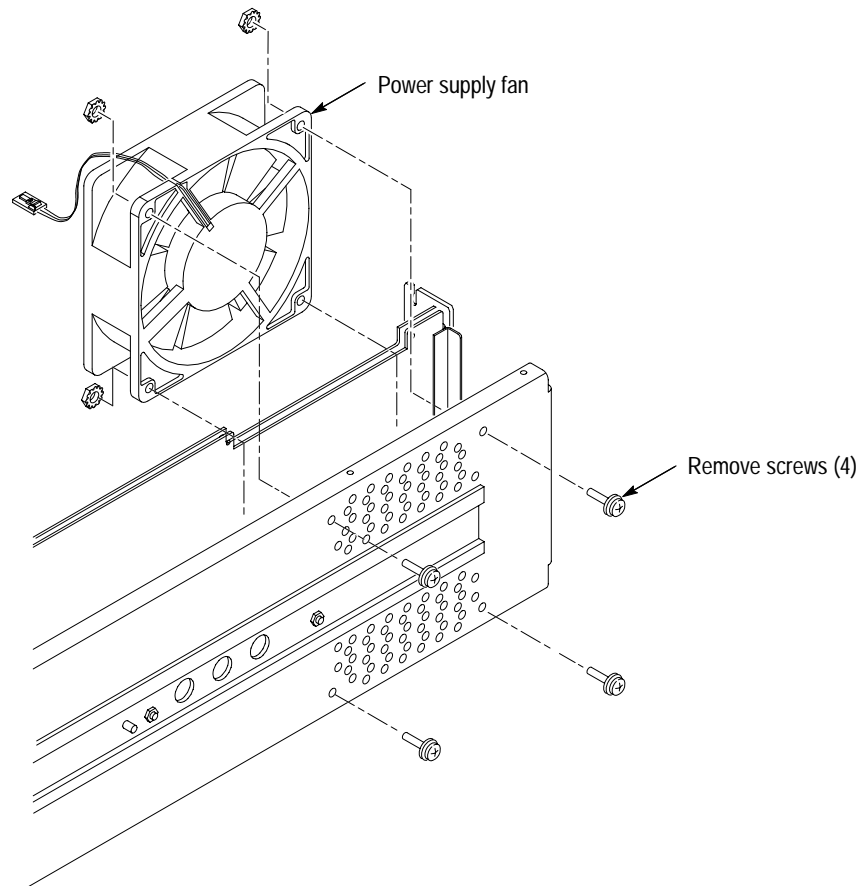

Figure 6–23: Removing the Power Supply board fan

Clock Module Fan. To remove the Clock module fan, perform the following procedure:

1. Remove the Clock module. Refer to *Clock Module* on page 6–31.
2. Disconnect the fan cable from the Backplane board.
3. Remove the four attaching nuts from the Clock module fan and lift the fan from the chassis. See Figure 6–24.

To replace the Clock board fan, perform the following procedure:

1. Position the fan so that the air-flow indicator on the fan housing points toward the outside of the instrument and so that the fan cable is on the bottom of the fan.
2. Install the four attaching nuts.

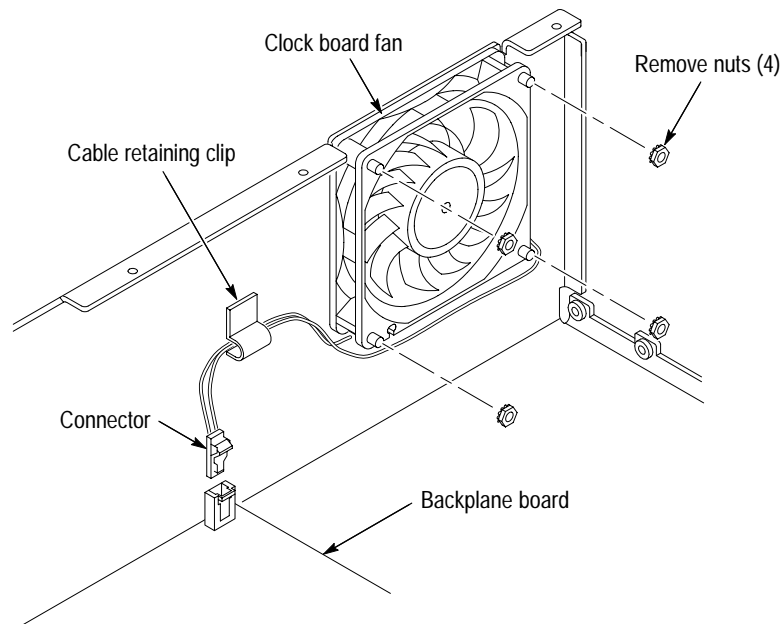

Figure 6–24: Removing the Clock board fan

3. Connect the fan cable to the connector on the Backplane board. Dress the fan cable behind the retaining clip. See Figure 6–24.
4. Install the Clock module. Refer to *Clock Module* on page 6–31.

Backplane Board and Shield

To remove the Backplane board and shield, perform the following procedure:

1. Remove the top cover. Refer to *Top Cover* on page 6–11.
2. Remove the Power Supply module. Refer to *Power Supply Module* on page 6–21.
3. Remove the CPU module. Refer to *CPU Module* on page 6–27.
4. Remove the Clock module. Refer to *Clock Module* on page 6–31.
5. Remove all installed generator or special function modules.
6. Disconnect the backup battery cable and Clock module fan cable from the Backplane board.
7. Remove the 12 attaching screws on the Backplane board and lift the circuit board from the chassis. See Figure 6–25.

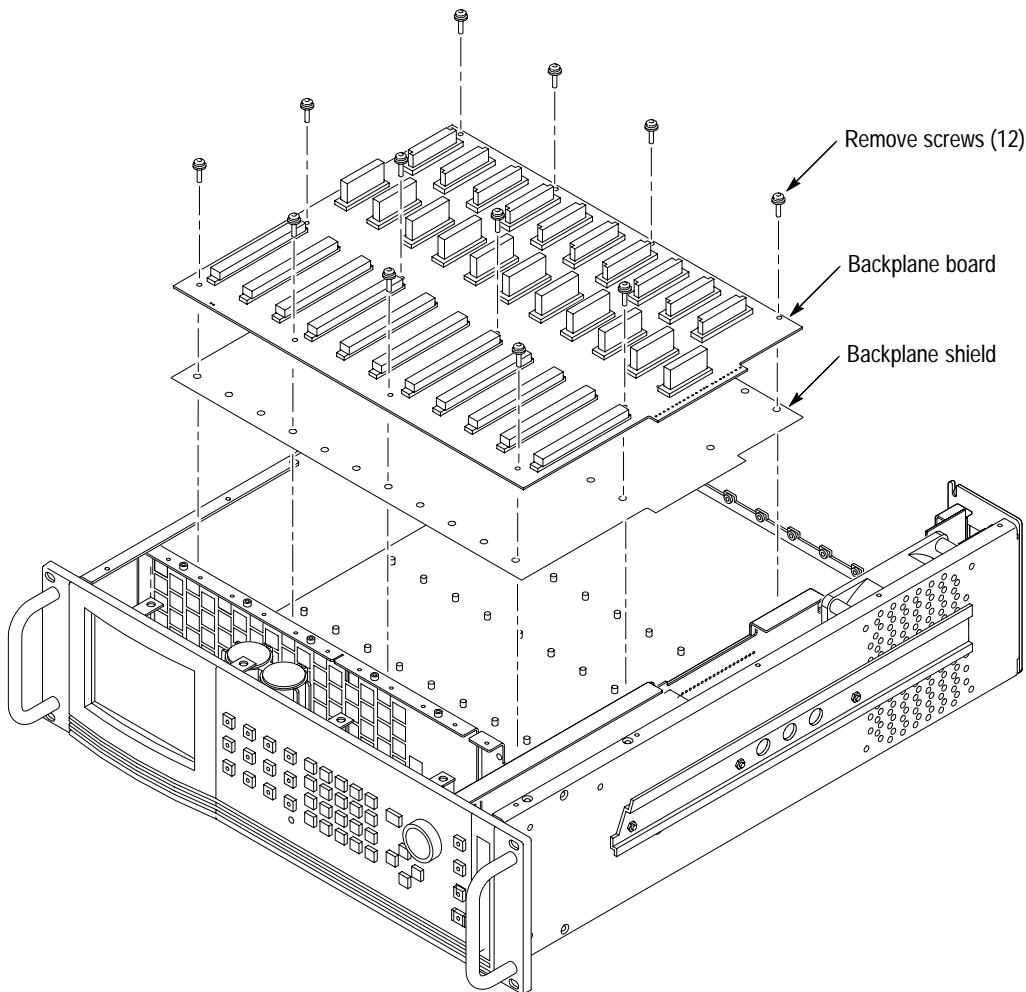

Figure 6–25: Removing the Backplane board

To replace the Backplane board and shield, perform the following procedure:

1. Align the shield under the Backplane board and install the 12 attaching screws on the Backplane board.
2. Connect the backup battery cable and Clock module fan cable to the Backplane board.
3. Install the Clock module. Refer to *Clock Module* on page 6–31.
4. Install the CPU module. Refer to *CPU Module* on page 6–27.
5. Install the Power Supply module. Refer to *Power Supply Module* on page 6–21.
6. Install the top cover. Refer to *Top Cover* on page 6–11.

Backup Battery

To remove the backup battery, perform the following procedure:



CAUTION. To prevent the loss of data, leave the instrument in standby mode when you replace the backup battery.

1. Remove the front-frame assembly. Refer to *Front Frame* on page 6–12.
2. Remove the two retaining screws from the battery.
3. Disconnect the two wires from the battery.

To replace the backup battery, perform the following procedure:

1. Connect the two wires to the battery. See Figure 6–26.
2. Install the two retaining screws into the battery.
3. Install the front-frame assembly. Refer to *Front Frame* on page 6–12.

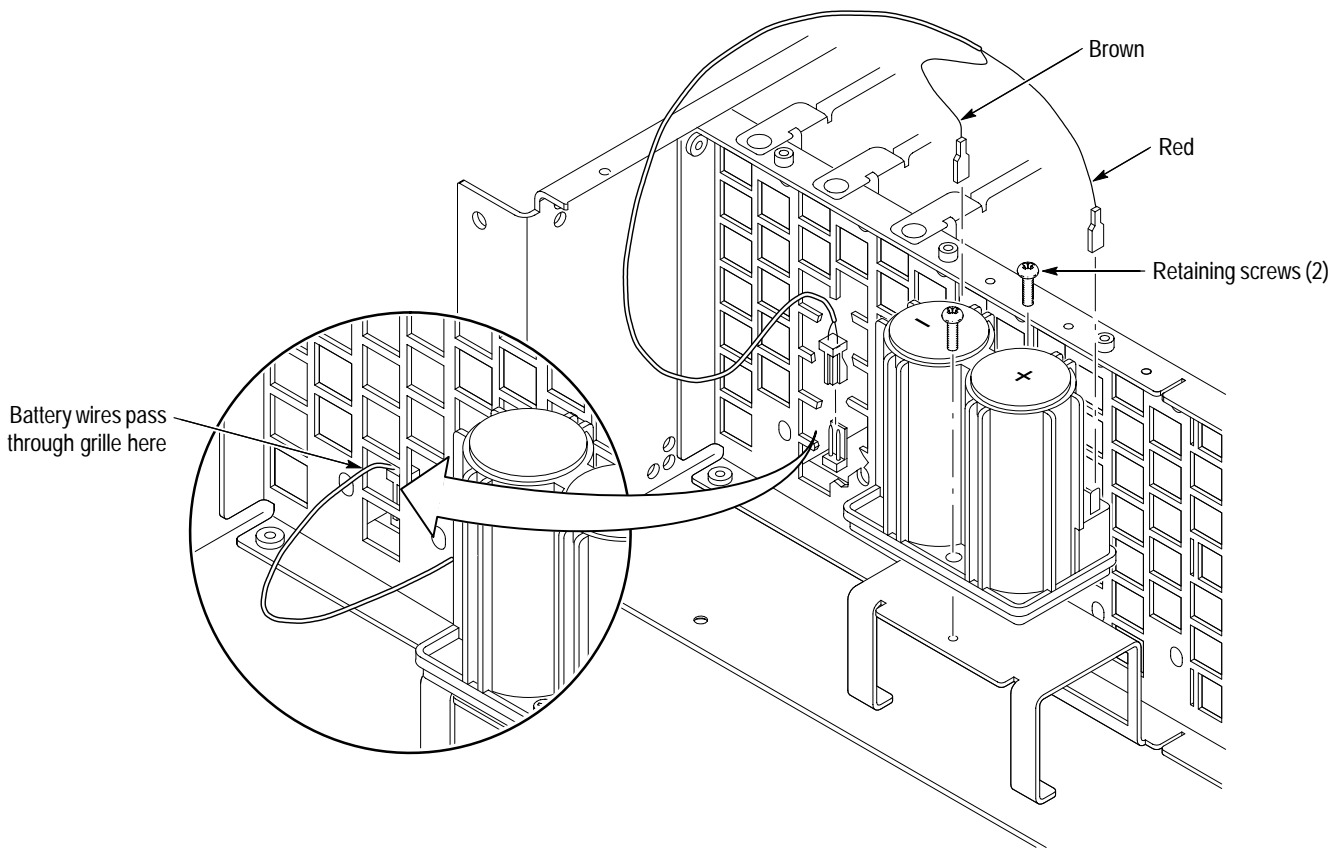

Figure 6–26: Replacing the battery

Troubleshooting Procedures

The troubleshooting procedures enable you to isolate faults within the TG 2000 Platform mainframe to the module level. This is limited to modules that are part of the mainframe, such as the power supply and CPU. To troubleshoot faults involving another module, such as a generator module, refer to the service manual for that module.

Equipment Required

The equipment listed in Table 6–3 is required for troubleshooting.

Table 6–3: Equipment required for troubleshooting

Equipment	Minimum requirements/example
Torx screwdriver handle	Accepts Torx-driver bits
T-10 and T-20 Torx tips	Torx-driver bit for T-10 and T-20 screw heads
Cross-tip screwdriver	
Voltmeter with probes	Accurate to two decimal places and measure AC voltage of 900 V _{RMS} . For example, the Tektronix DM2510 Digital Multimeter.
Floppy disk	MS-DOS preformatted, 3.5 inch

General Troubleshooting Procedures

This section contains general troubleshooting instructions and procedures to use when you begin to troubleshoot suspected faults with the instrument. If the instrument does not boot up or if the display is not working, refer to *Fault Symptom Table* on page 6–40.

Before you begin to troubleshoot suspected faults, perform the following steps if the instrument is able:



CAUTION. To prevent data loss, backup the instrument before you begin any troubleshooting procedures. Refer to *Instrument Backup* below for instructions.

1. Back up the instrument if it is already on. Refer to *Instrument Backup* on page 6–38.
2. Write the Console Ring file to disk. Refer to *Saving the Console Ring File to Disk* on page 6–39.

3. Turn the instrument off and then back on.
4. Write the Console Ring file to disk again (rerun the loaded sequence). Name this Console Ring file differently than the first Console Ring file.
5. Read the bootup messages and watch for errors. If errors occur, remove the top cover from the instrument and check that all cable connections are good. Check that the connector pins on the Backplane board are not bent or damaged and that all module subassemblies are properly seated.
6. If the CPU module fails the confidence test, refer to *CPU Confidence Test Codes* on page 6–40.
7. Refer to the *Troubleshooting* section of the service manual for any generator module that has error messages displayed during the bootup process.
8. Refer to *Fault Symptom Table* on page 6–40.

Instrument Backup

Perform the following procedure before you begin to troubleshoot the TG 2000 Platform mainframe. If the floppy drive is not functioning, refer to Figure 6–33 on page 6–44. After the problem is solved, restore instrument signals from the backup disks.

1. Load the **Troubleshooting** disk (supplied in this manual) into the floppy drive.
2. Press the front-panel **Sequences** button.
3. Touch **File Utilities**, and then touch **Add Sequences from Disk**.
4. Select the **tgbackup.seq** sequence file, and then touch **Start Load**.
5. Touch **OK, Quit**, and then **Quit** again.
6. Touch **Sequences** and then select the **tgbackup.seq** file to run.
7. Touch **Run** and then follow the instructions on the screen.
8. To restore the instrument setup after troubleshooting, load and run the **tgrstore.seq** file. Insert the back up disk(s) that you created when prompted by messages on screen. Disks do not have to be inserted in any particular order.

Saving the Console Ring File to Disk

The TG 2000 Platform mainframe displays module diagnostic information during instrument power up. Any error messages are written to an internal file called the console ring file. Tektronix technicians can use the information in the console ring file to help troubleshoot a malfunctioning module.

NOTE. Write the console ring file to disk before performing troubleshooting to prevent the troubleshooting routines from overwriting the console ring file.

Write the file as follows:

1. Load the Troubleshooting disk (supplied with the *TG 2000 Signal Generation Platform Service Manual*) into the floppy drive. Press the front-panel **Sequences** button.
2. Touch **File Utilities**, and then touch **Add Sequences from Disk**.
3. Select the **consbak.seq** sequence file and then touch **Start Load**.
4. Touch **OK, Quit**, and then **Quit** again.
5. Touch **Sequences** and then select the **consbak.seq** file to run (use the **Select** key).
6. Touch **Run**. Insert a blank disk when prompted, and touch **Quit**. Label this disk #1.
7. Turn the instrument off and then back on from the front panel. Wait until the instrument has completed its power up process.
8. Write the console ring file to disk again, using a different disk. Label this disk #2.
9. Read the console ring file power up messages. If there are errors, refer to the *Fault Symptom Table* on page 6–40.

Returning Modules to Tektronix

When you return a mainframe or module to Tektronix for repair or replacement, be sure to include the following:

- The disks containing the console ring files.
- Information about whether or not the module passed diagnostics, the highest number reached for that module, and any error messages.
- Description of the problem, including which troubleshooting flow chart you used.

CPU Confidence Test Codes

The CPU diagnostic LED displays an error code when the CPU module fails a confidence test. The confidence tests are run sequentially and stop when an error is found. If an error is found during the third confidence test, tests four, five, and six are not run.

Table 6-4: CPU confidence test codes

Error code	Confidence test	Action required
1	Verify LCD controller is responding	Replace CPU module
2	Test LCD memory	Replace CPU module
3	Test NVRAM	Replace CPU module
4	Test DRAM	Check CPU Memory board seating. Replace CPU Memory board or CPU module.
5	Test FLASH	Replace CPU module
6	Test floppy drive	Check floppy drive. Replace CPU module.

Fault Symptom Table

Before proceeding, be sure you have saved the console ring file as indicated in *General Troubleshooting* on page 6-39.

Use the fault symptom table when the instrument does not boot up or has display problems, or after you have performed the general troubleshooting procedure on page 6-37.

Locate your fault symptom in Table 6-5 and go to the indicated flowchart to isolate the faulty module.

Table 6-5: Fault symptom table

Symptom	Flowchart
Instrument does not boot up properly or has bad display	page 6-41
Backlight does not illuminate	page 6-42
Front panel does not function	page 6-43
Locked LED does not illuminate	page 6-44
Floppy drive does not operate	page 6-44
Instrument hot or fans do not operate	page 6-45
The correct time is not stored	page 6-46
Signal noise in slots 9 and 10 (SN B010391 and below only)	page 6-46
Instrument loses its signal and operating memory	page 6-47
Front-panel knob does not function properly	page 6-48

Troubleshooting Flowcharts

Follow the steps in the appropriate flowchart to isolate the faulty module. Each flowchart is directly related to a fault symptom listed in Table 6-5.

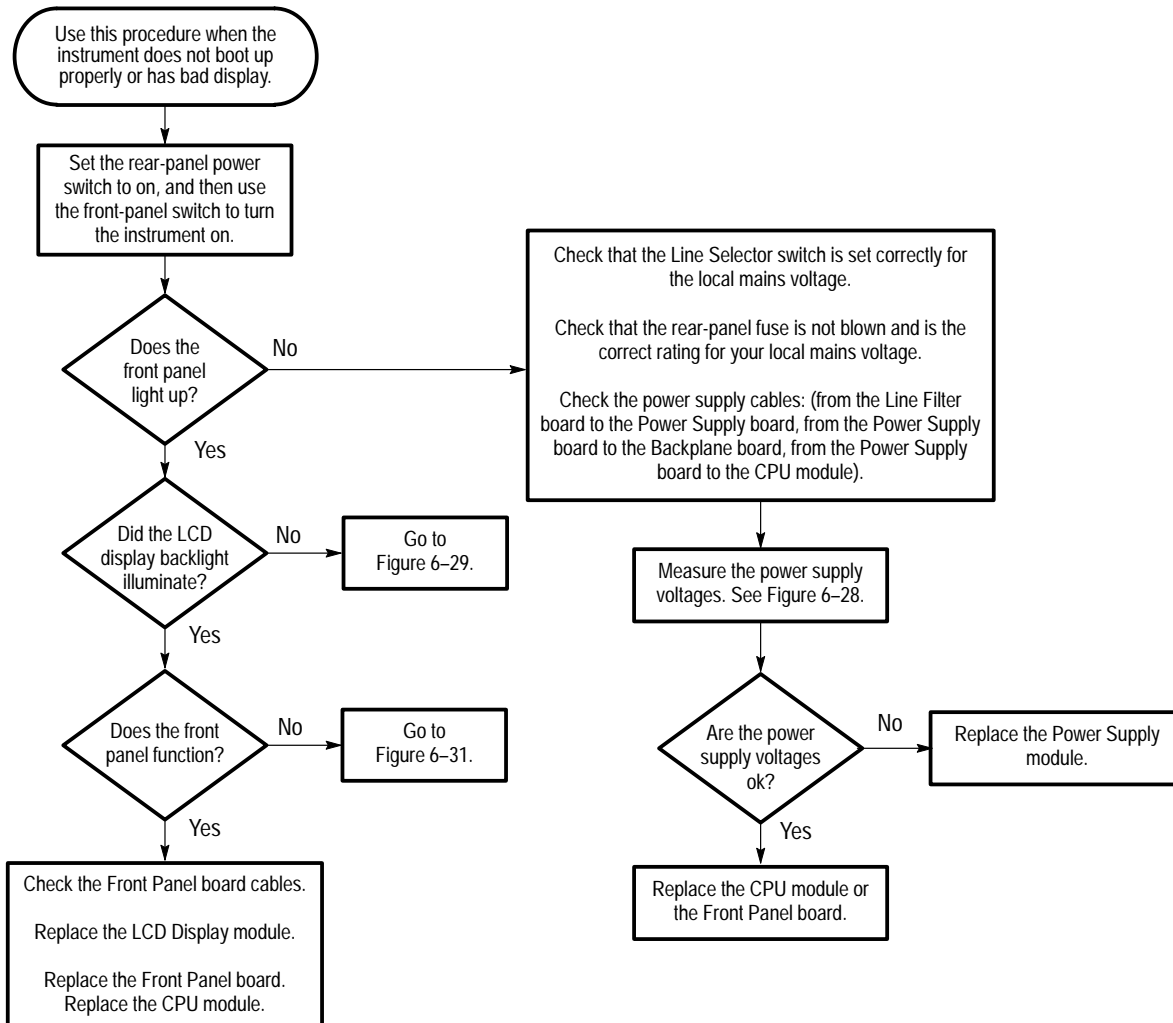

Figure 6-27: Instrument does not boot up properly

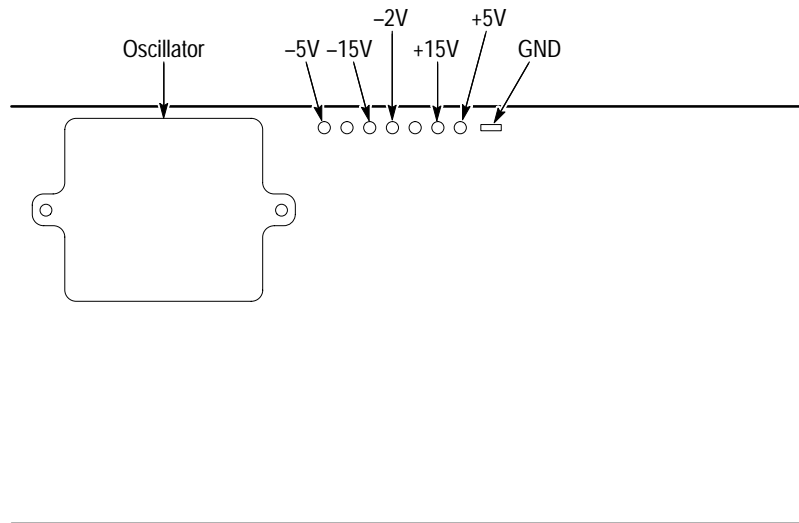

Figure 6-28: Measuring the power supply voltages on the clock board

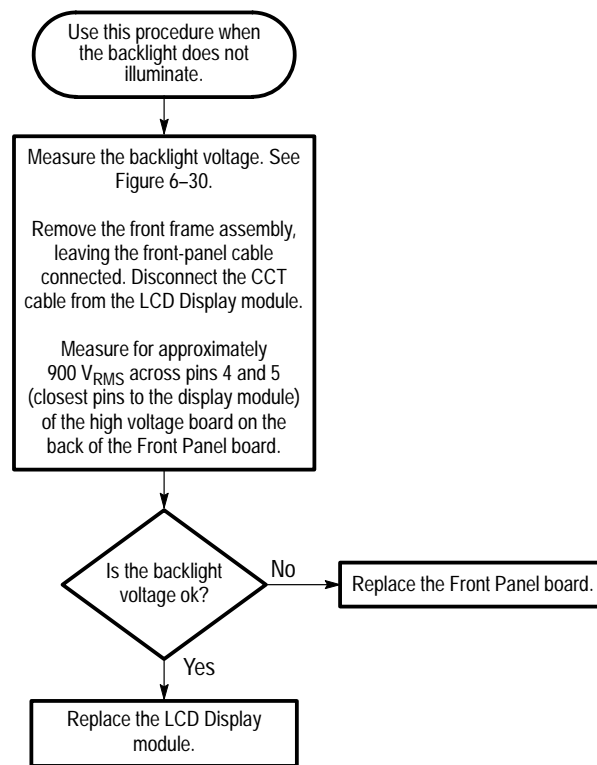

Figure 6-29: Backlight does not illuminate

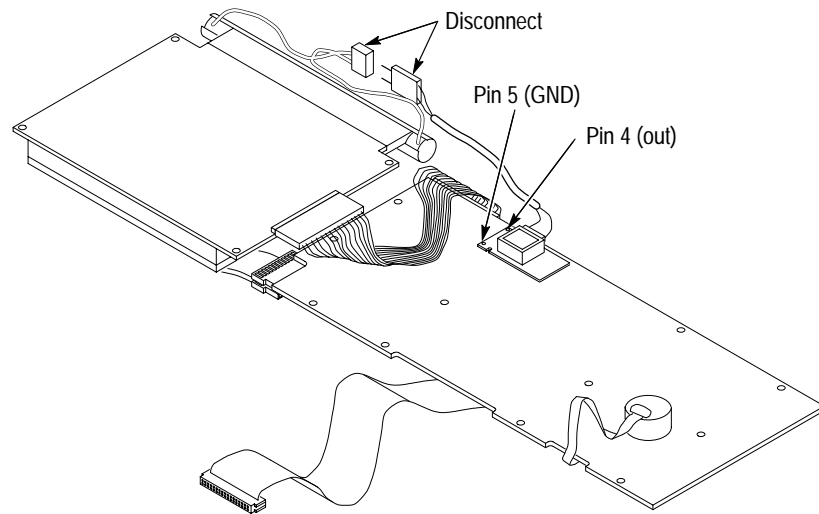

Figure 6–30: Measuring the LCD Display module high voltage

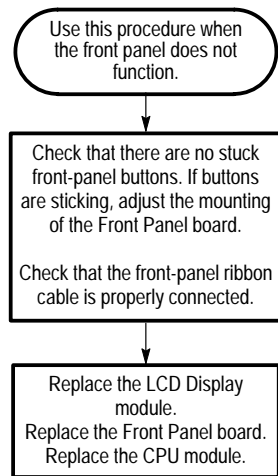

Figure 6–31: Front panel does not function

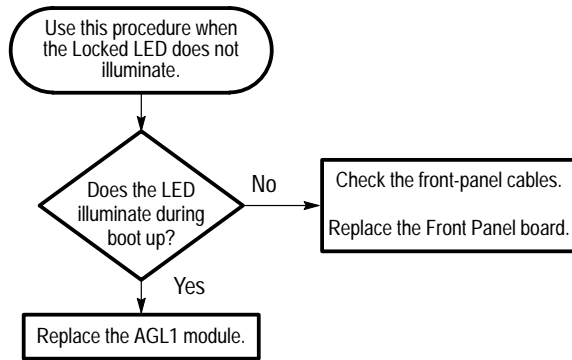

Figure 6-32: Locked LED does not illuminate

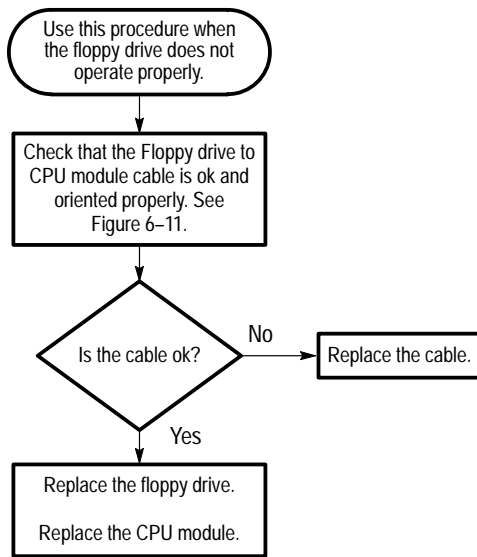

Figure 6-33: Floppy drive does not operate properly

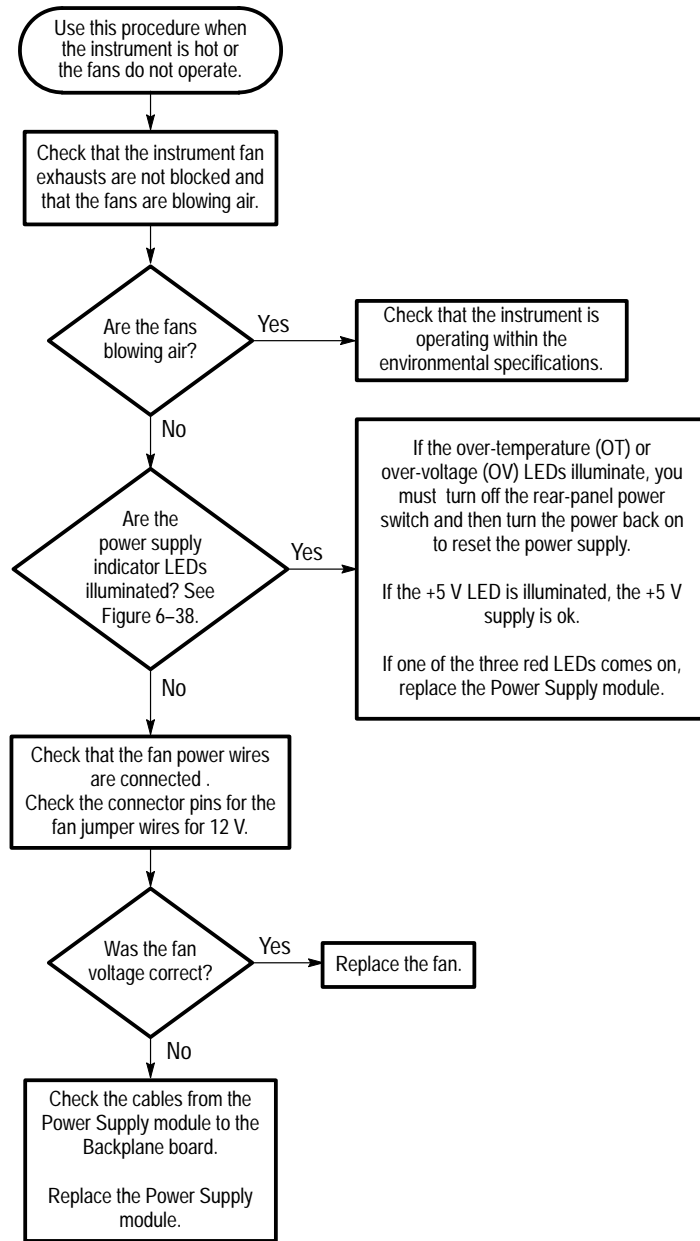

Figure 6-34: Instrument is hot or the fans do not operate

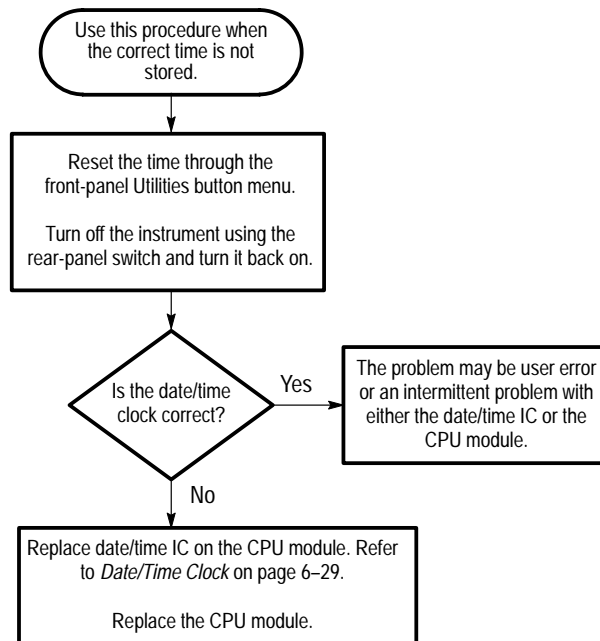

Figure 6-35: Correct time is not stored

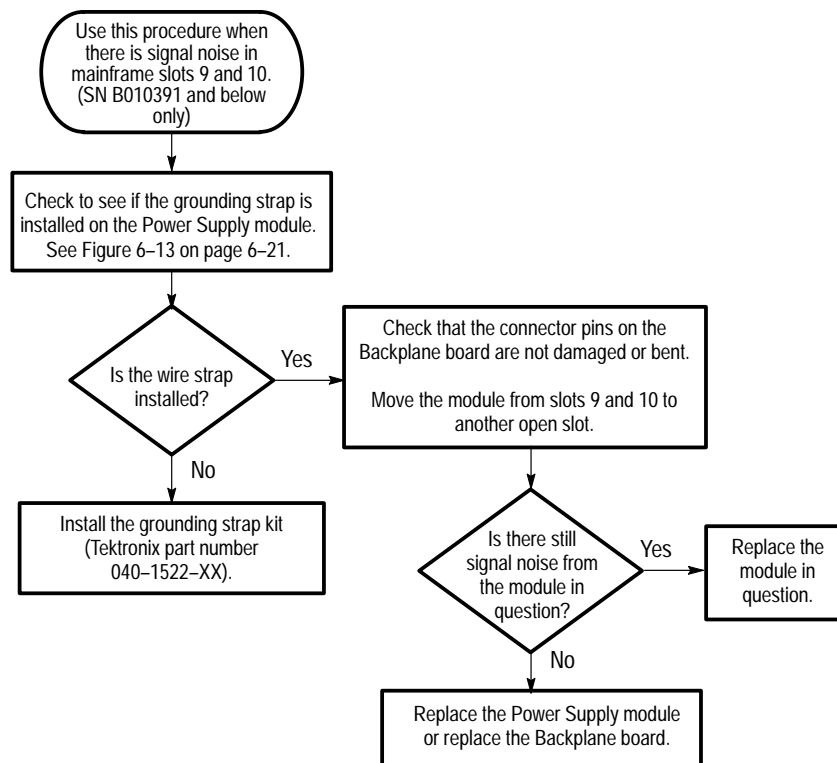

Figure 6-36: Signal noise in mainframe slots 9 and 10

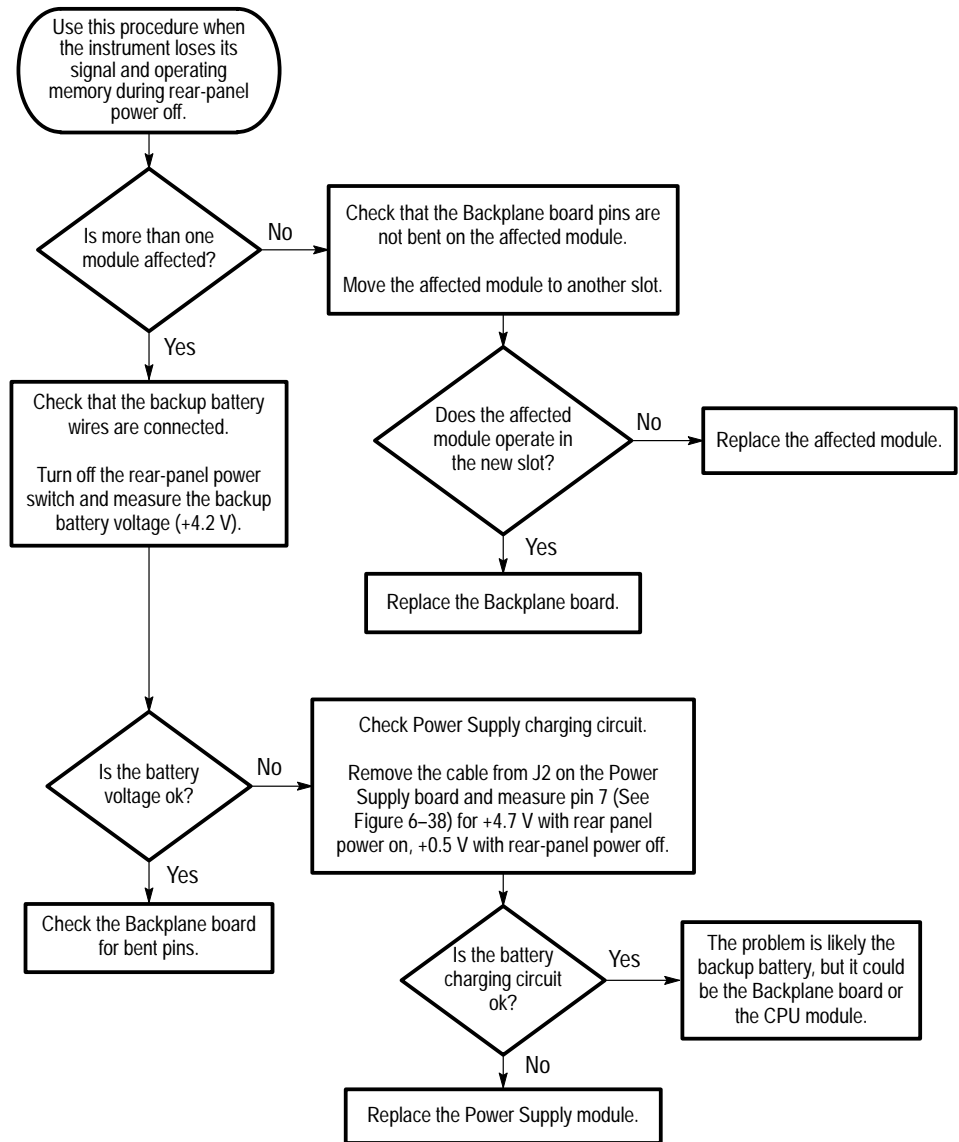

Figure 6-37: Instrument loses signal and operating memory during rear-panel power off

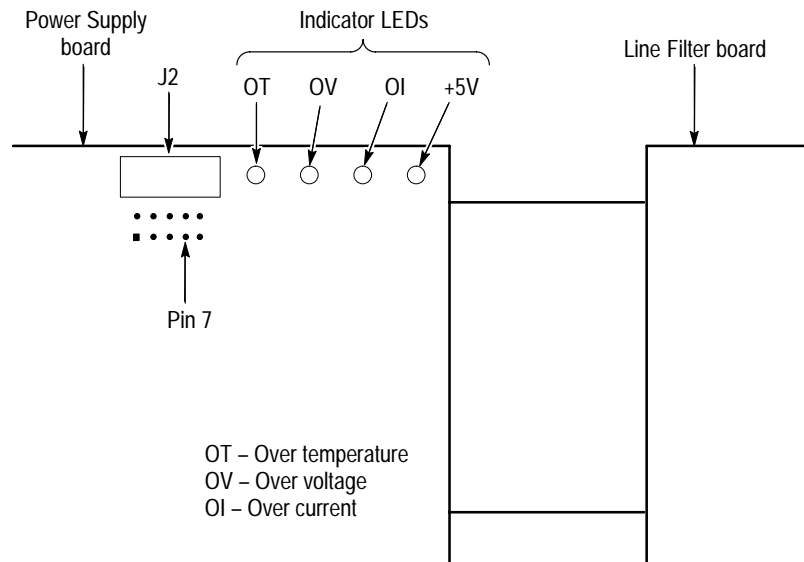

Figure 6-38: Measuring the battery charging circuit

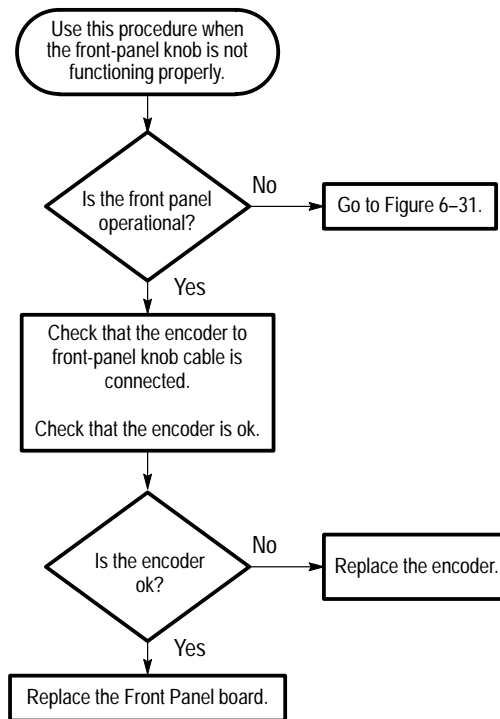

Figure 6-39: Front-panel knob does not function properly

Options

The only instrument options available with the TG 2000 Platform mainframe are the power cord options. Check the module manuals for information on options available with modules.

You can purchase the mainframe with one of the power cord options shown in Table 7-1. Power cord part numbers are shown in the *Replaceable Mechanical Parts* list.

Table 7-1: Power cord identification

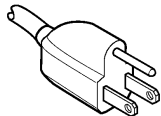
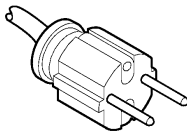
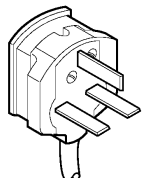
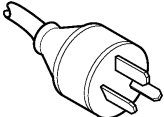
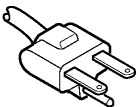
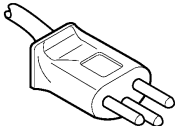
Plug configuration	Normal usage	Option number
	North America 125 V/15A Plug NEMA 5-15P	Standard
	Europe 230 V	A1
	United Kingdom 230 V	A2
	Australia 230 V	A3
	North America 230 V	A4
	Switzerland 230 V	A5



Replaceable Electrical Parts

The electrical modules for the TG 2000 Signal Generation Platform, such as the battery, circuit boards, and fuses, are included in the *Replaceable Mechanical Parts* list. Since component-level repair is not supported, individual electrical components are not listed.

Diagrams

The diagrams in this section show how the generator modules and special function modules connect with the mainframe (Backplane board), with each other, and with other equipment (outputs).

Mainframe Interconnect Diagrams

Figure 9–1 shows the Backplane board (assembly A1), which is located on the bottom of the mainframe chassis. This board has a total of 11 slots. The diagram shows how the components of the system, including optional modules, plug into the Backplane board, and indicates which modules can be plugged into each slot.

Figure 9–2 shows the Front Panel board, Power Supply board and Line Filter connections and Figure 9–3 shows the Clock module connections.

Modules Interconnect Diagrams

Figures 9–4 through 9–8 show the generator and special function modules with their respective outputs and connections, including the Backplane board slots to which each module can be connected.

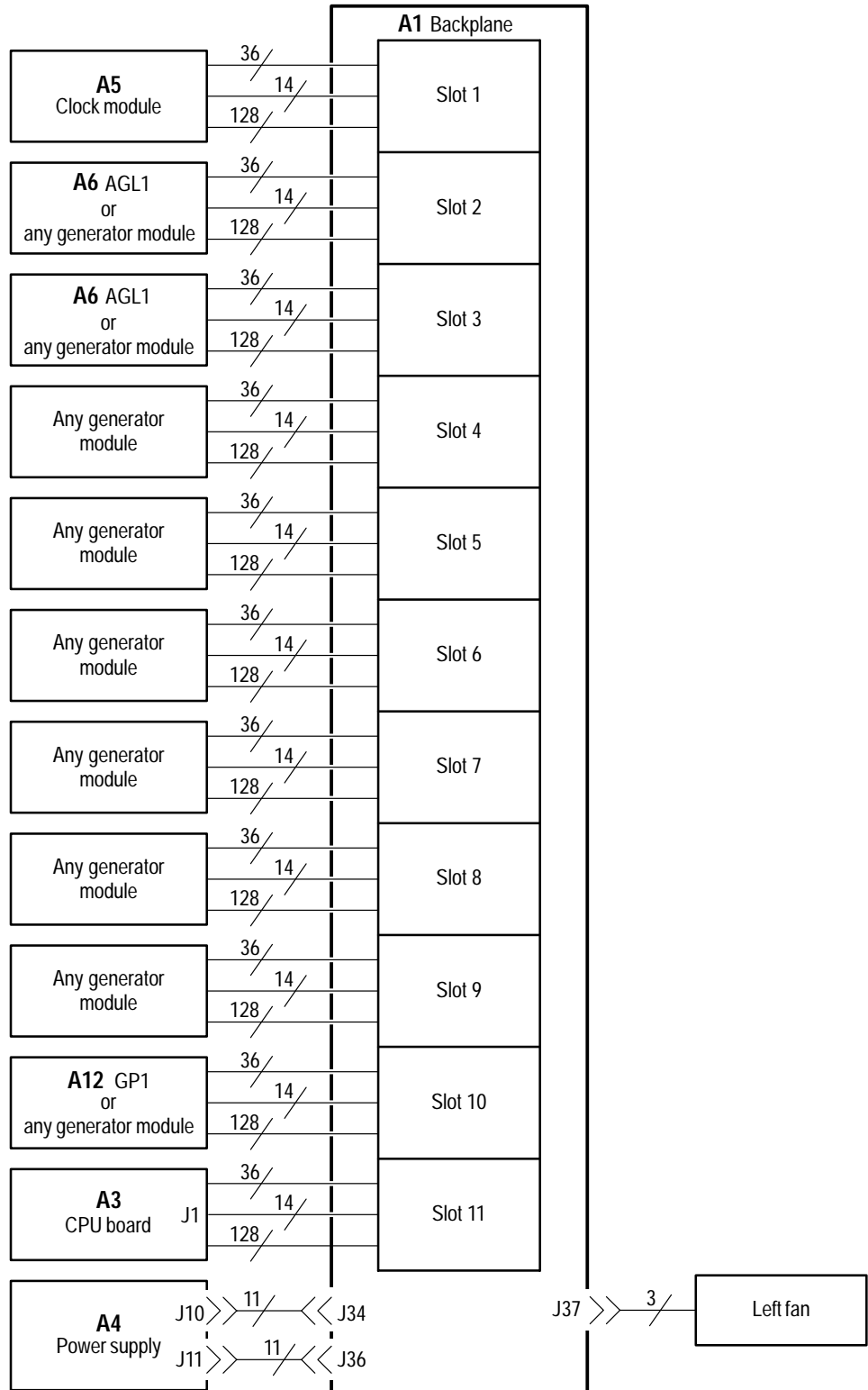

Figure 9-1: Backplane board connections

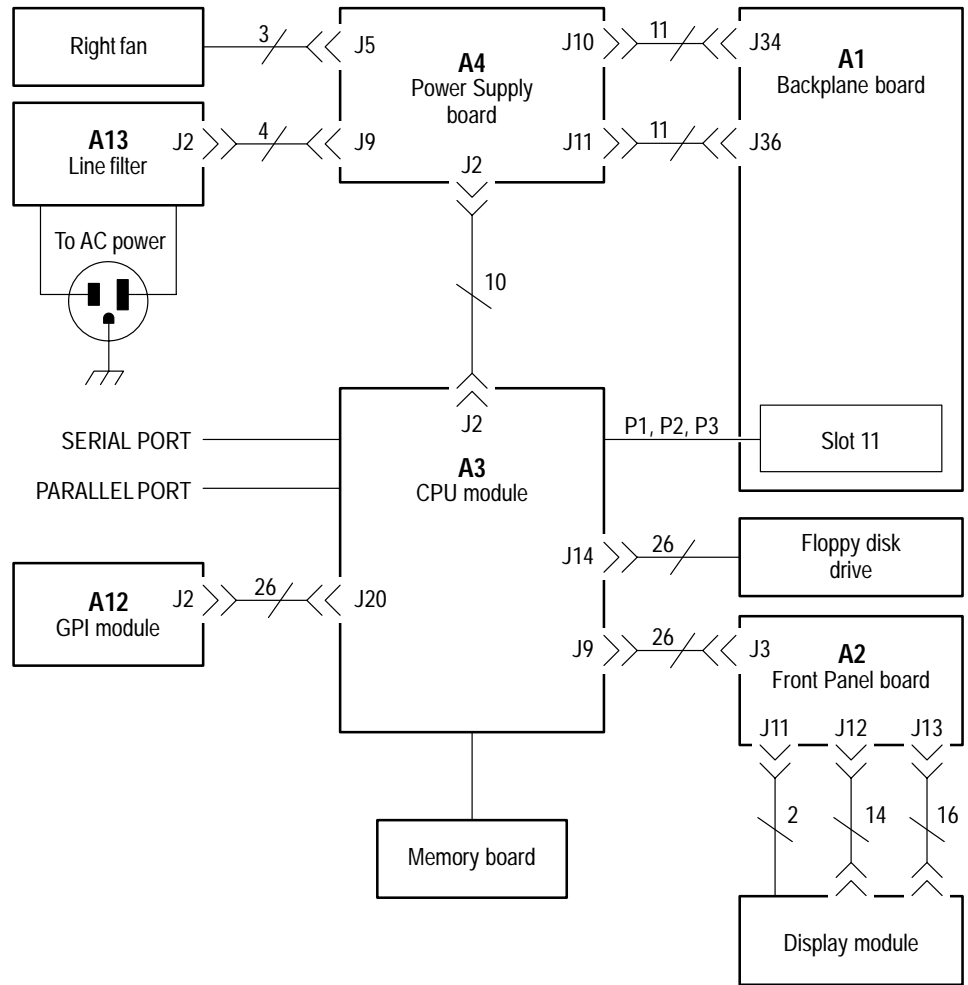

Figure 9-2: CPU, Front Panel board, Power Supply board and Line Filter connections

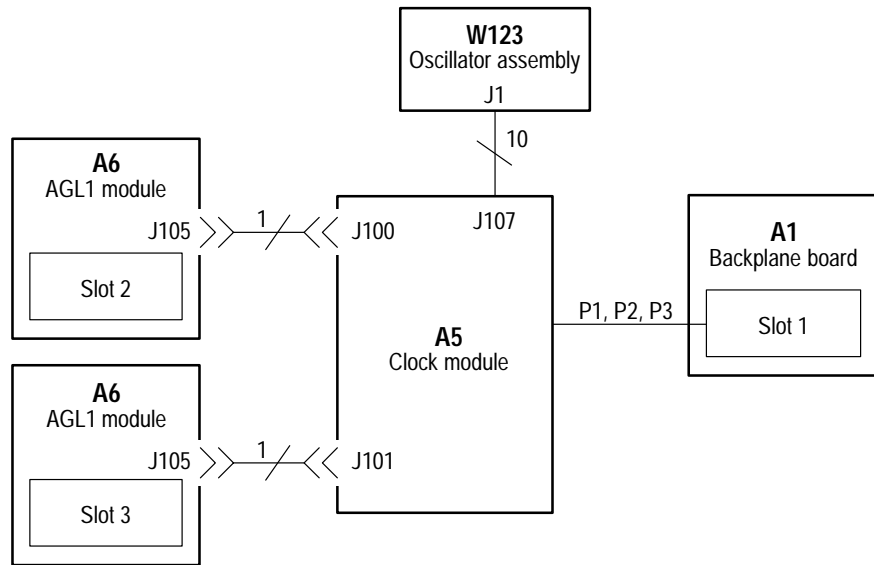

Figure 9-3: Clock connections

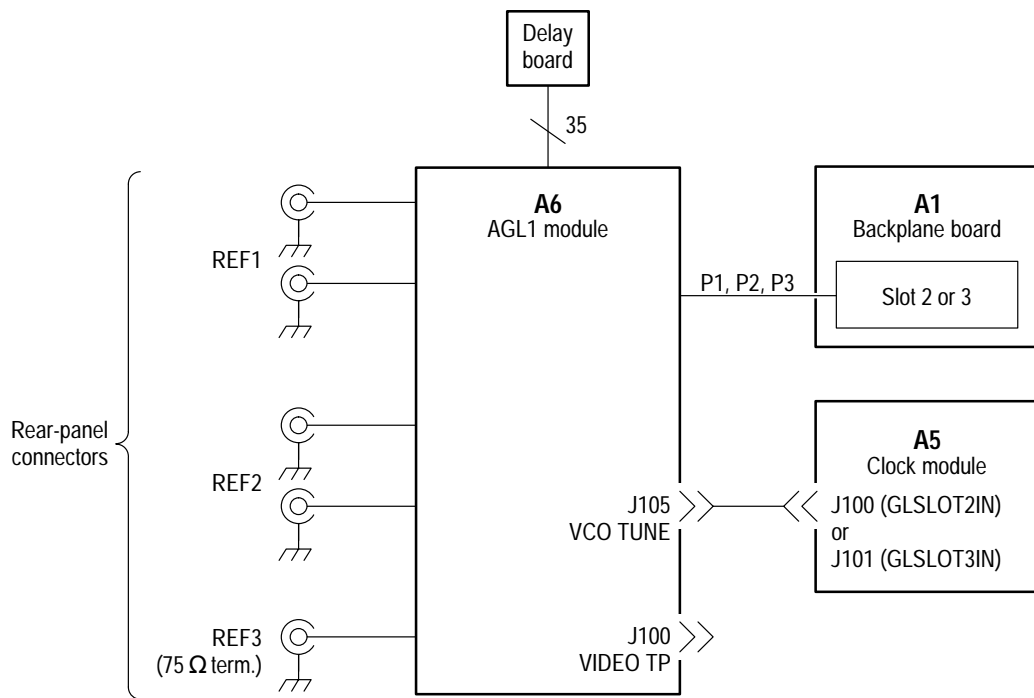

Figure 9-4: AGL1 module connections

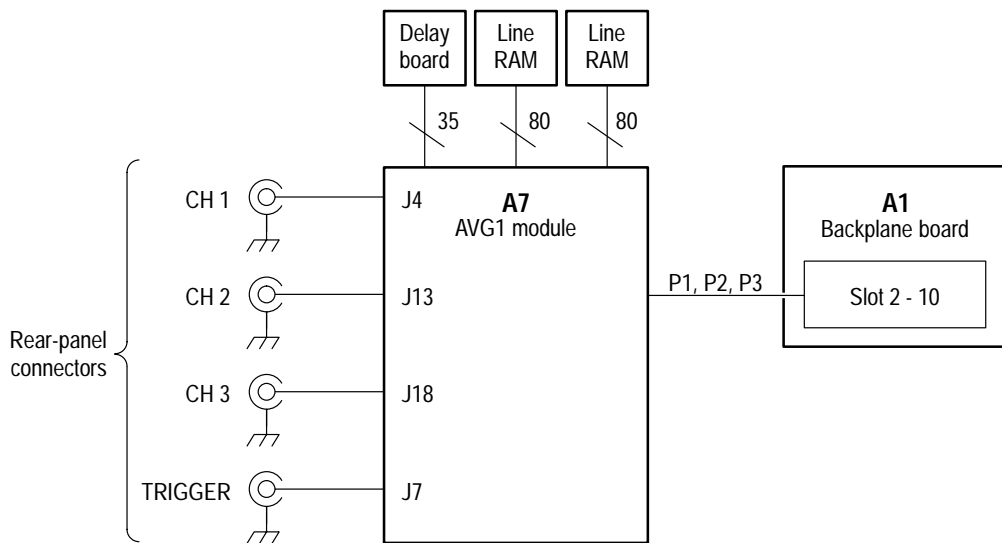

Figure 9-5: AVG1 module connections

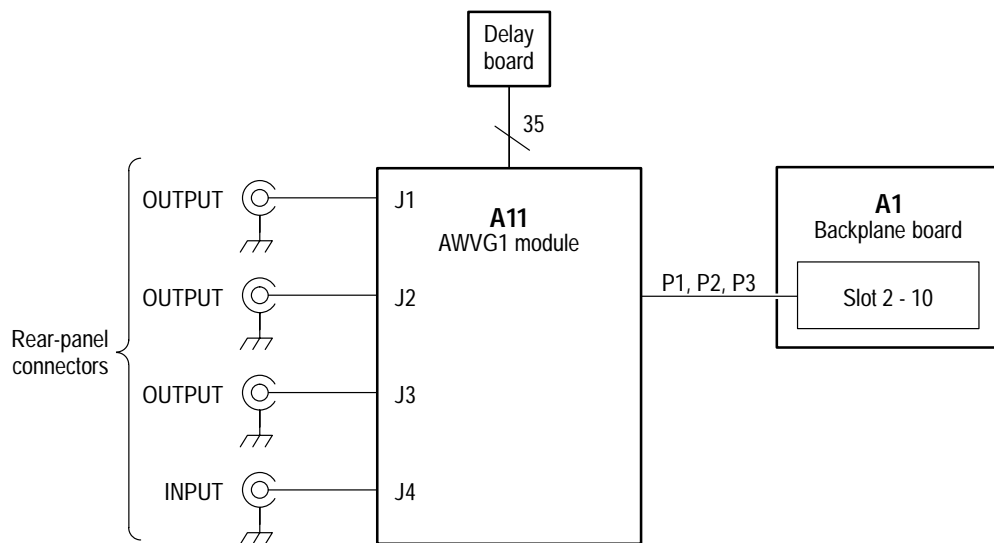

Figure 9-6: AWWG1 module connections

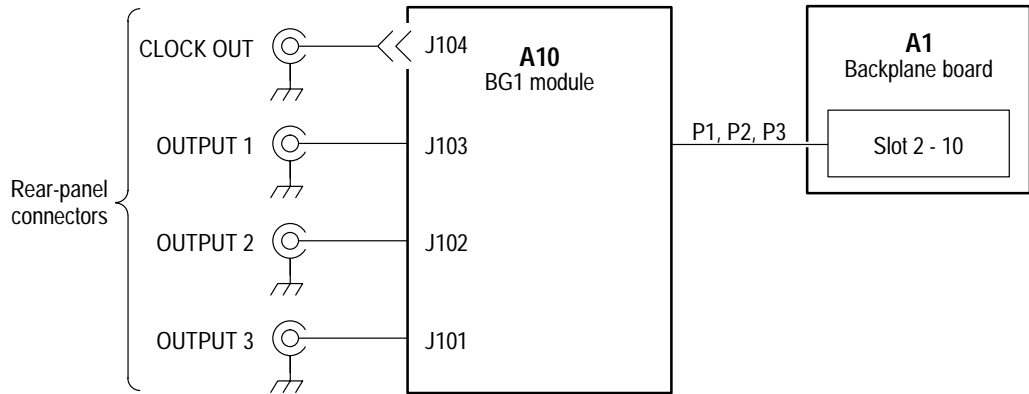

Figure 9-7: BG1 module connections

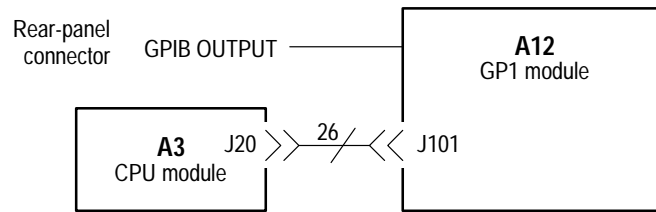

Figure 9-8: GP1 module connections

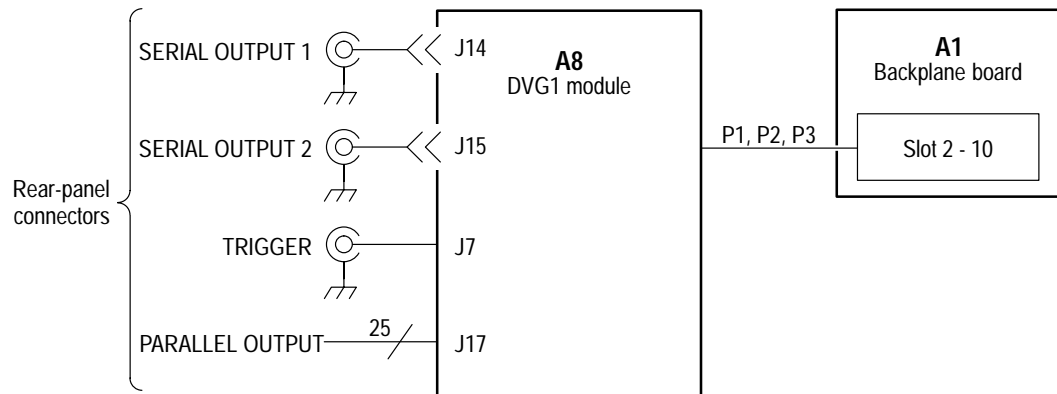

Figure 9–9: DVG1 module connections (standard)

NOTE. Figure 9–10 shows the connections with Option S1 installed as shipped. For information about using alternate connections, refer to the DVG1 Digital Video Generator User Manual.

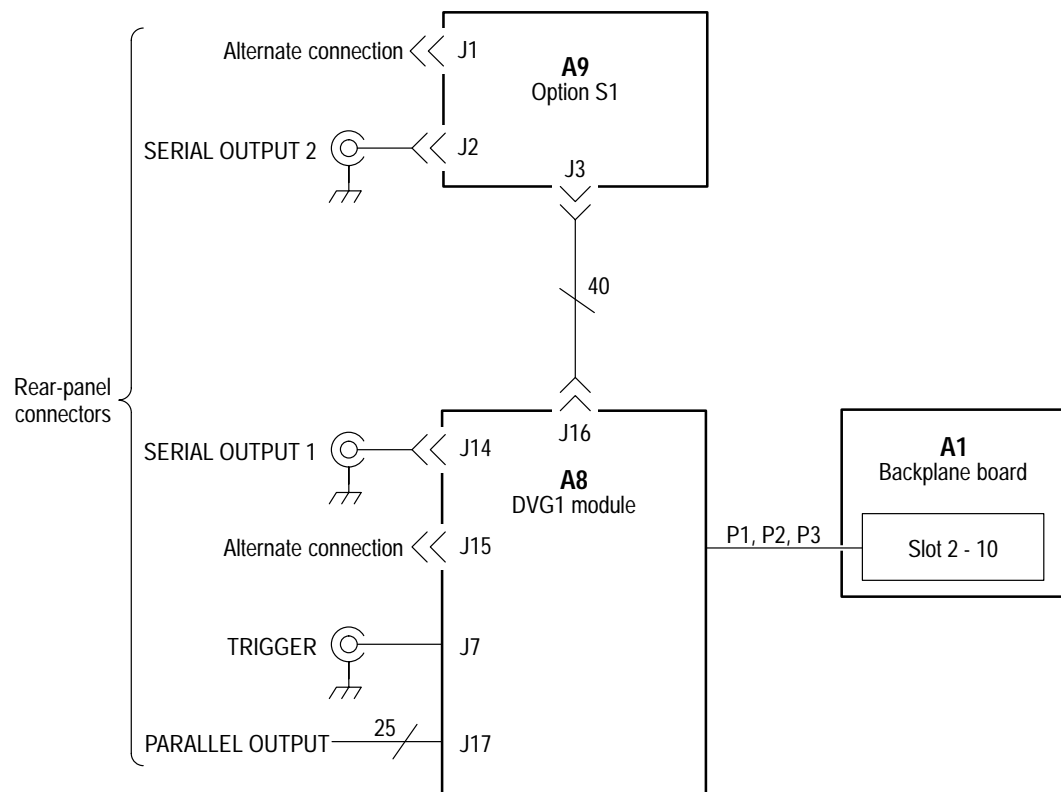

Figure 9–10: DVG1 module connections (with Option S1 installed as shipped)

Replaceable Parts

This section contains a list of the replaceable modules for the TG 2000 Signal Generation Platform. Use this list to identify and order replacement parts.

Parts Ordering Information

Replacement parts are available through your local Tektronix field office or representative.

Changes to Tektronix products are sometimes made to accommodate improved components as they become available and to give you the benefit of the latest improvements. Therefore, when ordering parts, it is important to include the following information in your order.

- Part number
- Instrument type or model number
- Instrument serial number
- Instrument modification number, if applicable

If you order a part that has been replaced with a different or improved part, your local Tektronix field office or representative will contact you concerning any change in part number.

Change information, if any, is located at the rear of this manual.

Module Servicing

Modules can be serviced by selecting one of the following three options. Contact your local Tektronix service center or representative for repair assistance.

Module Exchange. In some cases you may exchange your module for a remanufactured module. These modules cost significantly less than new modules and meet the same factory specifications. For more information about the module exchange program, call 1-800-TEK-WIDE, extension 6630.

Module Repair and Return. You may ship your module to us for repair, after which we will return it to you.

New Modules. You may purchase replacement modules in the same way as other replacement parts.

Using the Replaceable Parts List

This section contains a list of the mechanical and/or electrical components that are replaceable for the TG 2000 Signal Generation Platform. Use this list to identify and order replacement parts. The following table describes each column in the parts list.

Parts List Column Descriptions

Column	Column Name	Description
1	Figure & Index Number	Items in this section are referenced by figure and index numbers to the exploded view illustrations that follow.
2	Tektronix Part Number	Use this part number when ordering replacement parts from Tektronix.
3 and 4	Serial Number	Column three indicates the serial number at which the part was first effective. Column four indicates the serial number at which the part was discontinued. No entries indicates the part is good for all serial numbers.
5	Qty	This indicates the quantity of parts used.
6	Name & Description	An item name is separated from the description by a colon (:). Because of space limitations, an item name may sometimes appear as incomplete. Use the U.S. Federal Catalog handbook H6-1 for further item name identification.
7	Mfr. Code	This indicates the code of the actual manufacturer of the part.
8	Mfr. Part Number	This indicates the actual manufacturer's or vendor's part number.

Abbreviations Abbreviations conform to American National Standard ANSI Y1.1–1972.

Mfr. Code to Manufacturer Cross Index The table titled Manufacturers Cross Index shows codes, names, and addresses of manufacturers or vendors of components listed in the parts list.

Manufacturers Cross Index

Mfr. Code	Manufacturer	Address	City, State, Zip Code
80009	TEKTRONIX, INC.	P.O. BOX 500	BEAVERTON, OR, 97077-0001
06090	RAYCHEM CORP	300 CONSTITUTION DR	MENLO PARK, CA 94025-1111
06666	GENERAL DEVICES	PO BOX 39100	INDIANAPOLIS, IN 46239
06915	RICHCO	5825 N TRIPP AVE P.O. BOX 804238	CHICAGO, IL 60646
01536	TEXTRON INC	1818 CHRISTINA ST	ROCKFORD, IL 61108
0B0A9	DALLAS SEMICONDUCTOR	4350 BELTWOOD PKWY S	DALLAS, TX 75244
OJR04	TOSHIBA AMERICA INC.	ELECTRONICS COMPONENTS DIV 9775 TOLEDO WAY	IRVINE, CA 92718
OKB01	STAUFFER SUPPLY CO	810 SE SHERMAN	PORTLAND, OR 97214-4657
1DM20	PARLEX CORP	7 INDUSTRIAL WAY	SALEM, NH 03079
2K262	BOYD CORPORATION	6136 NE 87TH AVENUE	PORTLAND, OR 97220
32559	BIVAR INC	4 THOMAS ST	IRVINE, CA 92718
32997	BOURNS INC	TRIMPOT DIVISION 1200 COLUMBIA AVE	RIVERSIDE, CA 92507-2114
50356	TEAC AMERICA INC	7733 TELEGRAPH RD PO BOX 750	MONTEBELLO, CA 90640-6537
54186	MICRO POWER SYSTEMS INC	3151 JAY ST	SANTA CLARA, CA 95054
5F520	PANEL COMPONENTS CORP	PO BOX 115	OSKALOOSA, IA 52577-0115
61058	MATSUSHITA ELECTRIC CORP OF AMERICA	PANASONIC INDUSTRIAL CO DIV TWO PANASONIC WAY	SECAUCUS, NJ 07094
61935	SCHURTER INC	1016 CLEGG CT PO BOX 750158	PETALUMA, CA 94975-0158
73893	MICRODOT INC	50631 E RUSSELL SCHMIDT BLVD	MT CLEMENS, MI 48045
7X318	KASO PLASTICS INC	11013 A NE 39TH	VANCOUVER, WA 98662
80126	PACIFIC ELECTRICORD CO	747 WEST REDONDO BEACH PO BOX 10	GARDENA, CA 90247-4203
85480	BRADY USA	NAMEPLATE DIVISION P O BOX 571 346 ELIZABETH BRADY RD	HILLSBOROUGH, NC 27278
93907	CAMCAR DIV OF TEXTRON INC	ATTN: ALICIA SANFORD 516 18TH AVE	ROCKFORD, IL 611045181
S3109	FELLER U.S. CORPORATION	72 VERONICA AVE UNIT #4	SOMERSET, NJ 08873
TK0435	LEWIS SCREW CO.	4300 SOUTH RACINE AVENUE	CHICAGO, IL 60609
TK1163	POLYCAST INC	9898 SW TIGARD ST	TIGARD, OR 97223
TK1547	MOORE ELECTRONICS INC	19500 SW 90TH CT PO BOX 1030	TUALATIN, OR 97062
TK1943	NEILSEN MANUFACTURING INC	3501 PORTLAND RD NE	SALEM, OR 97303
TK2376	CONDUCTIVE RUBBER TECH	22125 17TH AVE SE, SUITE 117	BOTHELL, WA 98021
TK2469	UNITREK CORPORATION	3000 LEWIS & CLARK HWY SUITE 2	VANCOUVER, WA 98661

Manufacturers Cross Index (Cont.)

Mfr. Code	Manufacturer	Address	City, State, Zip Code
TK2541	AMERICOR ELECTRONICS LTD	UNIT-H 2682 W COYLE AVE	ELK GROVE VILLAGE, IL 60007
TK2548	XEROX CORPORATION	DIV OF XEROX CORPORATION 14181 SW MILLIKAN WAY	BEAVERTON, OR 97005

Replaceable Parts List

Fig. & Index Number	Tektronix Part Number	Serial No. Effective	Serial No. Discont'd	Qty	Name & Description	Mfr. Code	Mfr. Part Number
1-1	211-0725-00			40	SCREW,MACHINE:6-32 X 0.375,FLH TORX	01536	ORDER BY DESCR
-2	200-4137-00			1	COVER, TOP:ALUMINUM	80009	200-4137-00
-3	119-5110-00			1	FAN,DC:TUBEAXIAL,12V,2.40W,80MM X 15MM	61058	FBA08T12H
-4	210-0457-00			4	NUT,PL,ASSEM WA:6-32 X 0.312,STL CD PL,W/LOCKWASHER	0KB01	ORDER BY DESCR
-5	333-4113-00			3	PANEL,REAR:ALUMINUM	80009	333-4113-00
-6	211-0408-00			12	SCR,ASSEM WSHR:4-40 X 0.250,PNH,STL,ZINC,T-10 TORX	0KB01	211-0408-00
-7	119-5087-00			1	FAN,DC:TUBEAXIAL,12V,120MM X 120MM X 38MM	80009	119-5087-00
-8	210-0458-00			12	NUT,PL,ASSEM WA:8-32 X 0.344,STL CD PL	73893	ORDER BY DESCR NO 841
-9	212-0189-00			4	SCR,ASSEM WSHR:8-32 X 0.500,PNH,STL,CDPL,T-20 TORX DR,MACHINE	0KB01	ORDER BY DESCRIPTION
-10	351-0104-03			1	SL SECT,DWR EXT:12.625 L,W/O HARDWARE	06666	C-720-3 (WITHOUT HARDWARE)
-11	337-4065-00			1	SHIELD:0.020 FR60 POLY	80009	337-4065-00
-12	671-2870-00			1	CIRCUIT BD ASSY:BACKPLANE	80009	671-2870-00
-13	441-2048-01	B010100	B010391	1	CHASSIS:CHASSIS,ALUM,WITH FANS AND BATTERY	80009	441-2048-01
	441-2048-02	B010392		1	CHASSIS:CHASSIS,ALUM,WITH FANS AND BATTERY	80009	441-2048-02
-14	-----			1	BRACKET:ALUMINUM,CARD GUIDE (PART OF CHASSIS ASSEMBLY)		
-15	337-4068-00			1	SHIELD:SHIELD,0.020 PLASTIC	80009	337-4068-00
-16	211-0507-00			2	SCREW,MACHINE:6-32 X 0.312,PNH,STL CD PL,POZ	TK0435	ORDER BY DESCR
-17	146-0110-00			1	BATTERY:4.0V,2.5A-H LEAD ACID SEALED BATTERY	54186	0819-0010
-18	174-3185-00			1	CA ASSY,PWR:DISCRETE,PSC,2,18 AWG,10.5L	80009	174-3185-00
-19	351-0782-00			11	GUIDE,CKT BD:NYLON,4.5 L	32559	DC-450
-20	343-0298-00			1	STRAP,RETAINING:0.25 DIA CABLE	06915	HUC-4

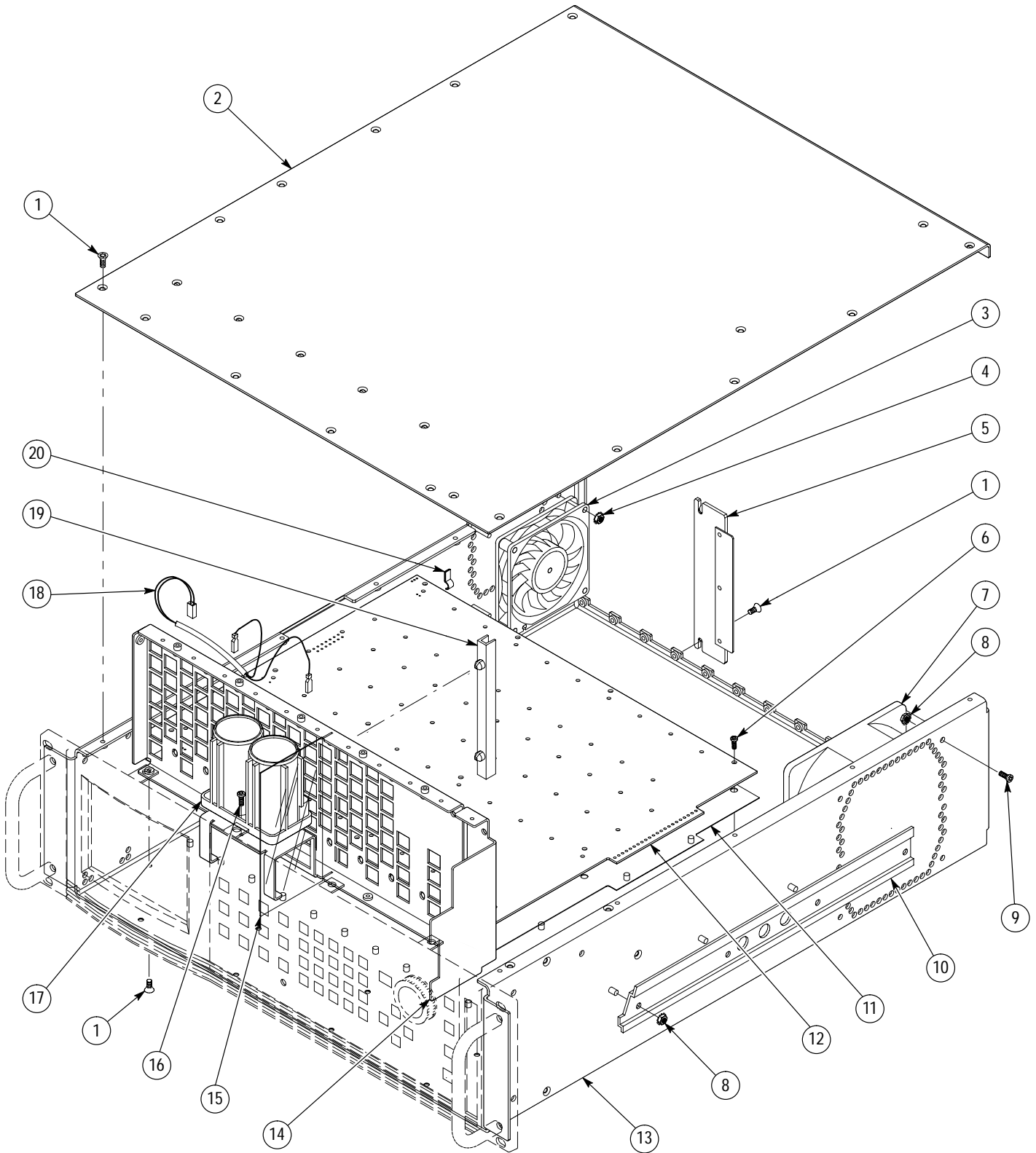

Figure 10-1: Top cover and chassis assembly

Fig. & Index Number	Tektronix Part Number	Serial No. Effective	Serial No. Discont'd	Qty	Name & Description	Mfr. Code	Mfr. Part Number
2-1	367-0450-00			2	HANDLE,BOW:CARRYING,3.75 CTR,10-32 THD 1.75 H	80009	367-0450-00
-2	426-2495-00			1	FRAME,FRONT:PLASTIC,POLYCARB	80009	426-2495-00
-3	174-3298-00			1	CA ASSY,SP:RIBBON,LCD,CPR,14,26 AWG,5.0 L	TK2469	174-3298-00
-4	200-4131-00			24	COVER,KEYCAP:PLASTIC,ABS	TK1163	200-4131-00
-5	671-2871-00			1	CIRCUIT BD ASSY:FRONT PANEL	80009	671-2871-00
-6	614-0933-00			1	ASSEMBLY,KIT:LCD DISPLAY MODULE	80009	614-0933-00
-7	211-0408-00			15	SCR,ASSEM WSHR:4-40 X 0.250,PNH,STL,ZINC,T-10 TORX	0KB01	211-0408-00
-8	212-0158-00			4	SCREW,MACHINE:8-32 X 0.375,PNH,STL,CDPL,T-20 TORX	0KB01	ORDER BY DESCR
-9	361-1679-00			1	SPACER:SPACER,CONNECTOR,4682	80009	361-1679-00
-10	311-2486-00			1	RES,VAR,PANEL:5K OHM, +/- 1%,1.5W,1.312D X 0.648L	32997	6657S-457-502
-11	119-4617-00			1	ELASTOMERIC,SW:SILICON RUBBER KEYPAD	TK2376	119-4617-00
-12	337-4055-00			1	SHIELD:SWITCH PROTECTOR SHIELD, PLASTIC,TV GRAY	7X318	337-4055-00
-13	200-4130-00			1	COVER,KEYCAP:PLASTIC,ABS	TK1163	200-4130-00
-14	174-3184-00			1	CA ASSY,SP:RIBBON,CPD,2,26 AWG,8.06,1X 3.0,1 CTR	TK1547	174-3184-00
-15	366-2174-00			1	KNOB:	80009	366-2174-00

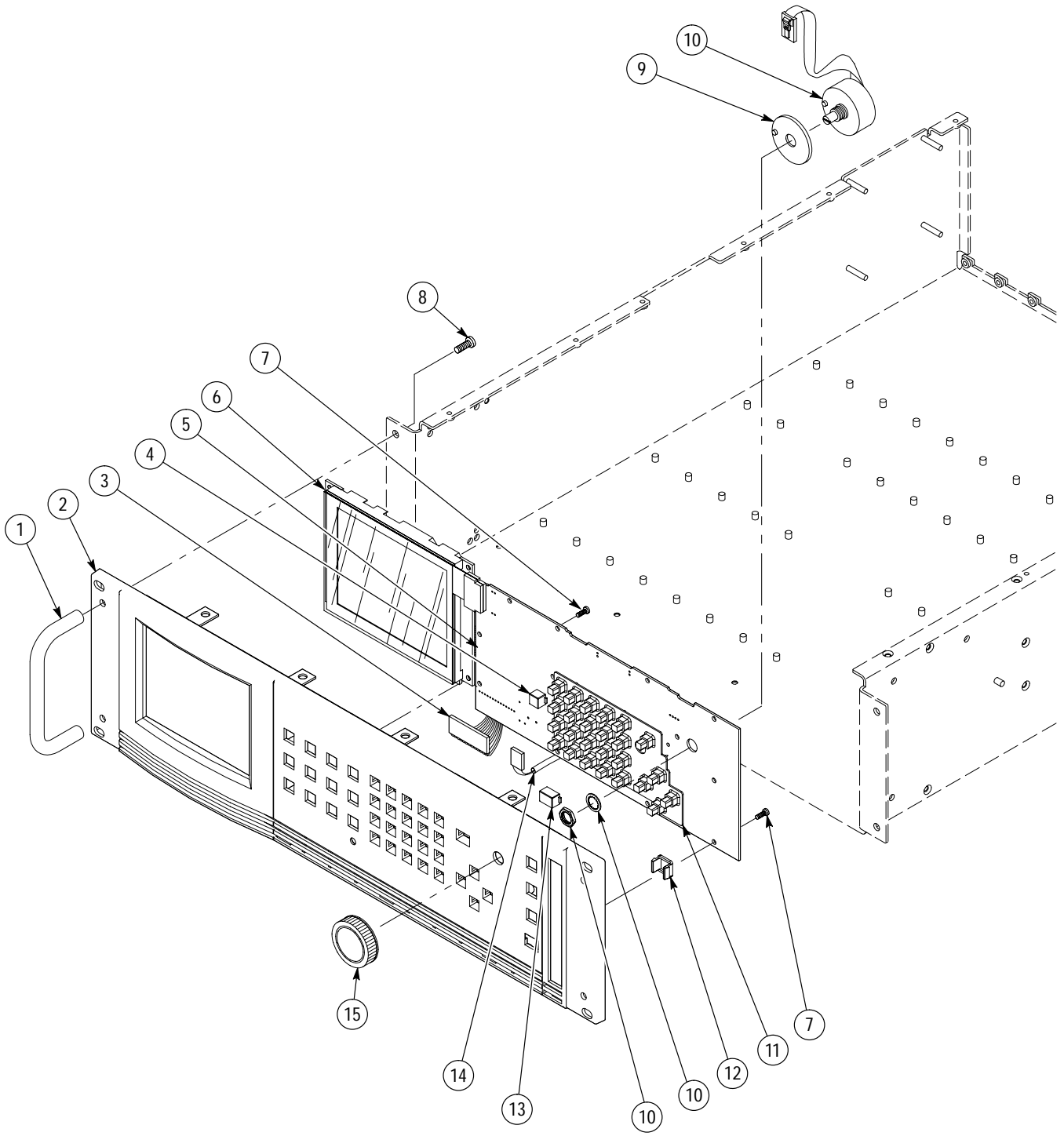

Figure 10-2: Front panel and display

Fig. & Index Number	Tektronix Part Number	Serial No. Effective	Serial No. Discont'd	Qty	Name & Description	Mfr. Code	Mfr. Part Number
3-1	211-0725-00			6	SCREW,MACHINE:6-32 X 0.375,FLH TORX	01536	ORDER BY DESCR
-2	337-4066-00			1	SHIELD,STEEL:DISK DRIVE ASSEMBLY SHIELD	80009	337-4066-00
-3	337-3990-01	B010100	B011099	1	SHIELD,ELEC:DISK DRIVE SHIELD,ALUM	80009	337-3990-01
	337-3990-02	B011100		1	SHIELD,ELEC:0.36 THK STL, ZI PLT,ETCH/CLR CHROMATEG,TG2000	TK1943	337-3990-02
-4	211-0840-00			3	SCREW,MACHINE:M2.6 X 0.45MM PITCH X 4.0MM L,PHILIPS	0KB01	.26C4MXPHY
-5	119-5413-01	B010100	B011099	1	DISK DRIVE:FLOPPY,3.5 INCH, 2M, 0.5 INCH DSDD	80009	119-5413-01
	119-5677-00	B011100		1	DISK DRIVE:FLOPPY,3.5 INCH,1.44MB,0.5 INCH HIGH, DSDD,FD-04HF-2300	50356	FD-04HF-2300
-6	337-4109-00	B010100	B011099	1	SHIELD:SHIELD,0.020 CLEAR PLASTIC	2K262	337-4109-00
-7	162-0676-00	B011100		.5 ft.	INSUL SLVG,ELEC:HT SHRINK,0.75 ID POLYOLEFIN,BLK	06090	VERSAFIT
-8	174-3135-00			1	CABLE ASSY,SP:FLAT FLEX,FLX,26,1MM,15.0 L	1DM20	1.00MM-26-15-B

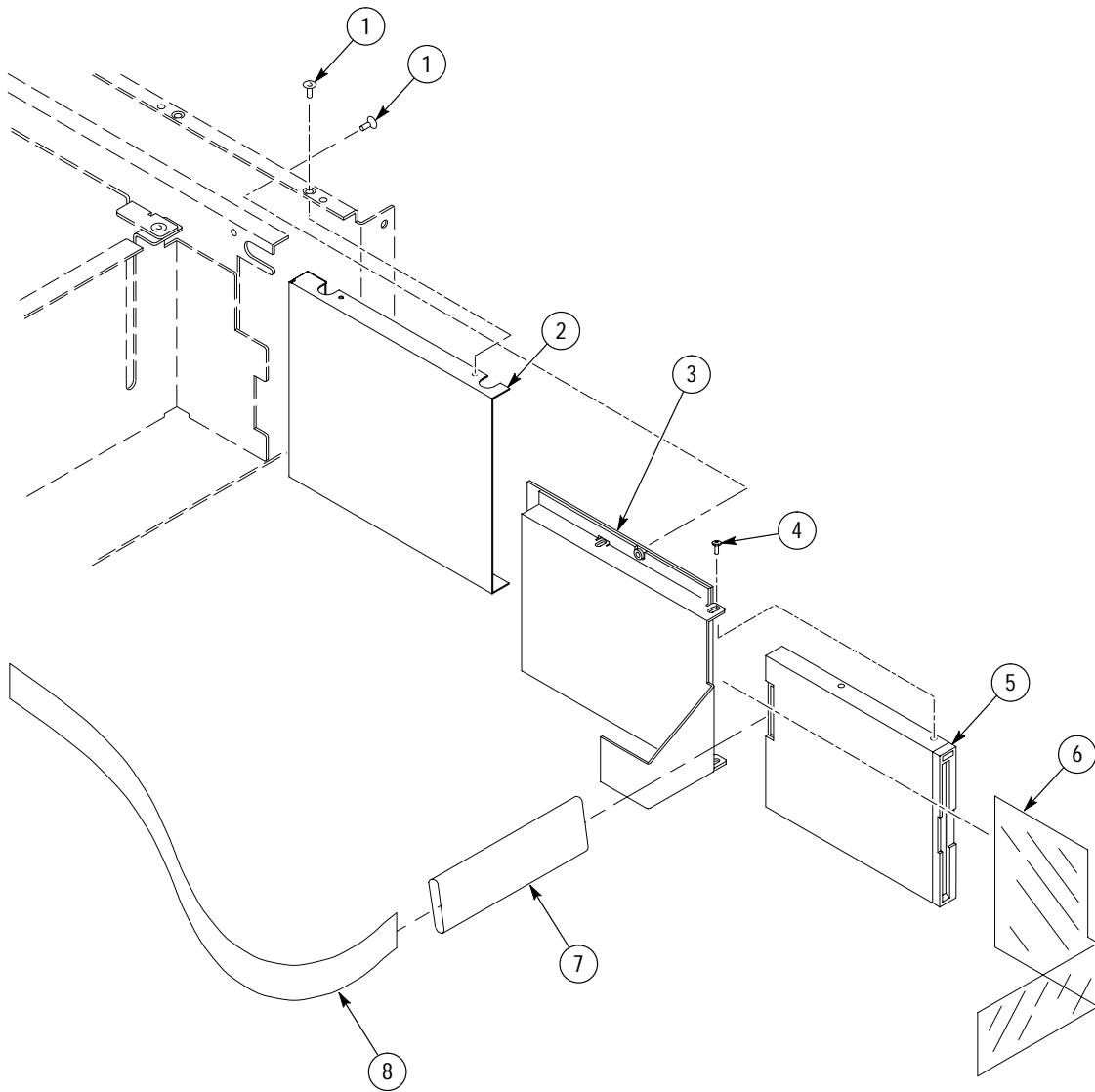

Figure 10-3: Disk drive assembly

Fig. & Index Number	Tektronix Part Number	Serial No. Effective	Serial No. Discont'd	Qty	Name & Description	Mfr. Code	Mfr. Part Number
4-	672-1489-00	B010100	B010391	1	MODULE ASSY:POWER SUPPLY,COMPLETE MODULE	80009	672-1489-00
	672-1489-01	B010392		1	MODULE ASSY:POWER SUPPLY,COMPLETE MODULE	80009	672-1489-01
-1	337-3938-00			1	SHIELD,ELEC:ALUMINUM	80009	337-3938-00
-2	337-3988-00			1	SHIELD:POWER SUPPLY,POLYCARBONATE,0.020,CLEAR	2K262	337-3988-00
-3	174-3111-00			2	CA ASSY,PWR:FLAT,IDC 22,18 AWG,5.0 L	TK2469	174-3111-00
-4	174-3470-00			1	CA,ASSY,SP:RIBBON,IDC,28 AWG,3.5 L	TK2469	174-3470-00
-5	198-5786-00			1	WIRE SET,ELEC:FUSE	TK1547	198-5786-00
-6	200-0237-04			1	COVER,FUHLR:PLASTIC	OJR05	ORDER BY DESCR
-7	204-0832-00			1	BODY,FUSEHOLDER:3AG & 5 X 20MM FUSES LOWPROFILE	61935	031 1673 (FEU MODEL)
-8	210-0873-00			1	WASHER,FLAT:0.5 ID X 0.688 OD X 0.047,RBR	0KB01	ORDER BY DESCR
-9	333-4098-00			1	PANEL,REAR:ALUMINUM,POWER SUPPLY,TG2000	TK1943	333-4098-00
-10	159-0342-00			1	FUSE,CARTRIDGE:6 AMP,250V,SLOW BLOW,0.250X 1.250 (FOR 115V OPERATION ONLY)	71400	MDL-6
	159-0005-00			1	FUSE,CARTRIDGE:3 AMP,250V,30SEC,UL LISTED, (FOR 230V OPERATION ONLY)	71400	MSL-3
-11	200-2264-00			1	CAP,FUSEHOLDER:3AG FUSES	61935	FEK 031 1666
-12	174-3554-00			1	CABLE,WIRE:WIRE ASSEMBLY,INCL ROCKER SWITCH	TK2469	174-3554-00
-13	211-0014-00			2	SCREW,MACHINE:4-40 X 0.5,PNH,STL CD PL,POZ	93907	ORDER BY DESCR
-14	131-3573-00			1	CONN,PLUG,ELEC:MALE,W/LOCKING ADAPTER	80126	B-0779
-15	211-0725-00			5	SCREW,MACHINE:6-32 X 0.375,FLH TORX	01536	ORDER BY DESCR
-16	337-3796-01			1	SHIELD,ELEC:0.032 BRASS,C26000,0.5 HARD	80009	337-3796-01
-17	671-2948-00			1	CKT BD ASSY:LINE FILTER	80009	671-2948-00
-18	211-0408-00			11	SCR,ASSEM WSHR:4-40 X 0.250,PNH,STL,ZINC,T-10 TORX	0KB01	211-0408-00
-19	174-3290-00			1	CA ASSY,SP:DISCRETE,CPM,2,18 AWG,35.0 L,1X3,0.156 CTR,RCPT,FRICTION LOCK X 0.25,FEMALE,FAS	TK2469	174-3290-00
-20	671-2873-00			1	CIRCUIT BD ASSY:POWER SUPPLY	80009	671-2873-00

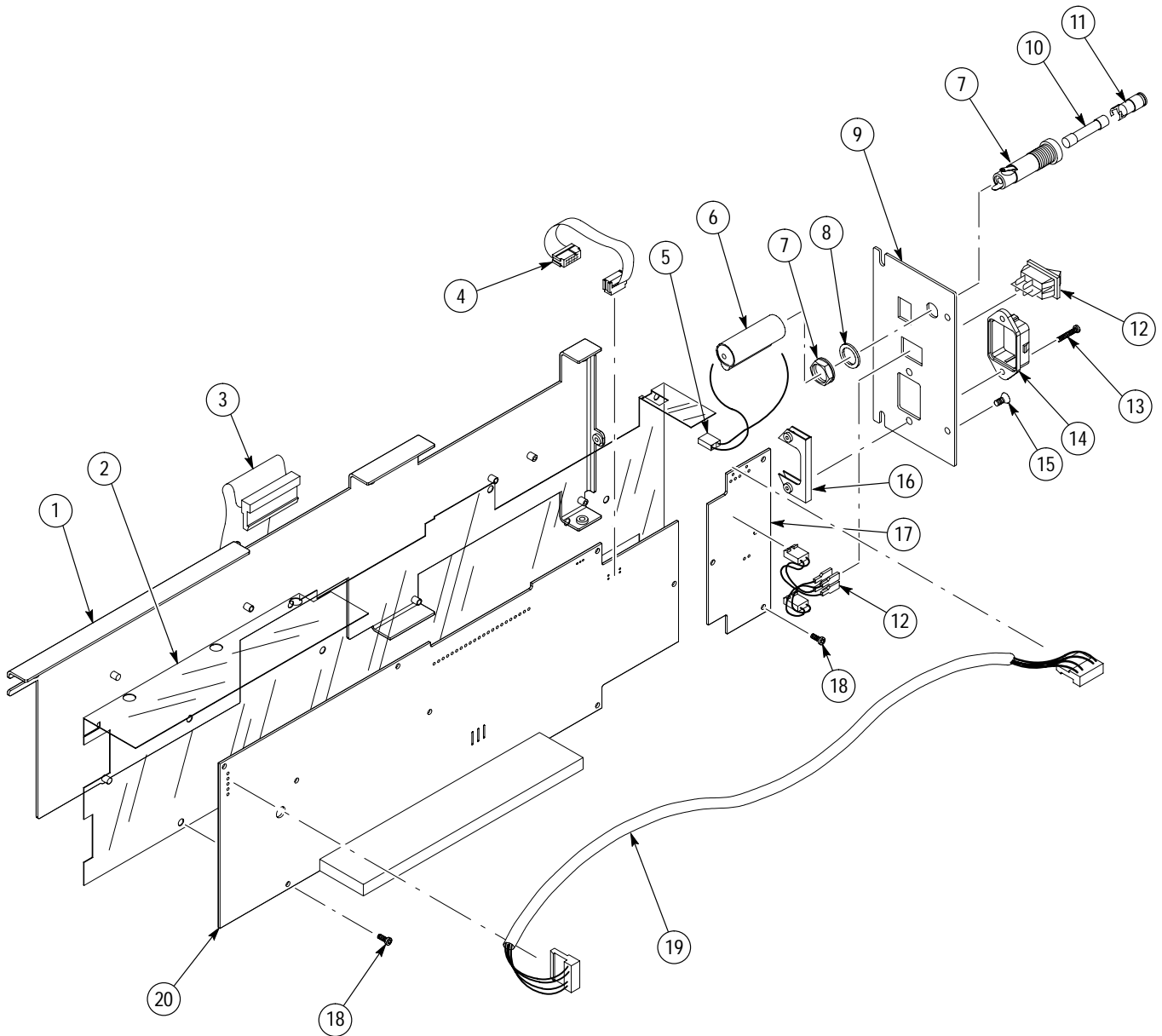

Figure 10-4: Power Supply module assembly

Fig. & Index Number	Tektronix Part Number	Serial No. Effective	Serial No. Discont'd	Qty	Name & Description	Mfr. Code	Mfr. Part Number
5-	672-1471-00			1	MODULE ASSY:CPU,COMPLETE MODULE	80009	672-1471-00
-1	211-0408-00			8	SCR,ASSEM WSHR:4-40 X 0.250,PNH,STL,ZINC,T-10 TORX	0KB01	211-0408-00
-2	211-0725-00			2	SCREW,MACHINE:6-32 X 0.375,FLH TORX	01536	ORDER BY DESCR
-3	671-2872-00	B010100	B010688	1	CIRCUIT BD ASSY:CONTROLLER	80009	671-2872-00
	671-2872-01	B010689		1	CIRCUIT BD ASSY:CONTROLLER	80009	671-2872-01
-4	156-4383-00			1	IC,MEMORY:CMOS,DRAM,2MEG X 32,70NS,MODULE,422000A32,SIMM72	0JR04	THM322020AS-70
-5	156-3543-00			1	IC,PROCESSOR:CMOS,PERIPHERAL,RTC, CLOCK CALENDAR WITH RAM & BATTERY	0B0A9	DS1287
-6	337-3937-01			1	SHIELD,ELEC:ALUMINUM W/PLASTIC SHIELD	80009	337-3937-00
-7	333-4099-00			1	PANEL,REAR:ALUMINUM,CONTROLLER	TK1943	333-4099-00
-8	214-3903-01			4	SCR,JACK:4-40 X 0.312 EXT THD,4-40 INT THD,0.188 HEX	0KB01	214-3903-01

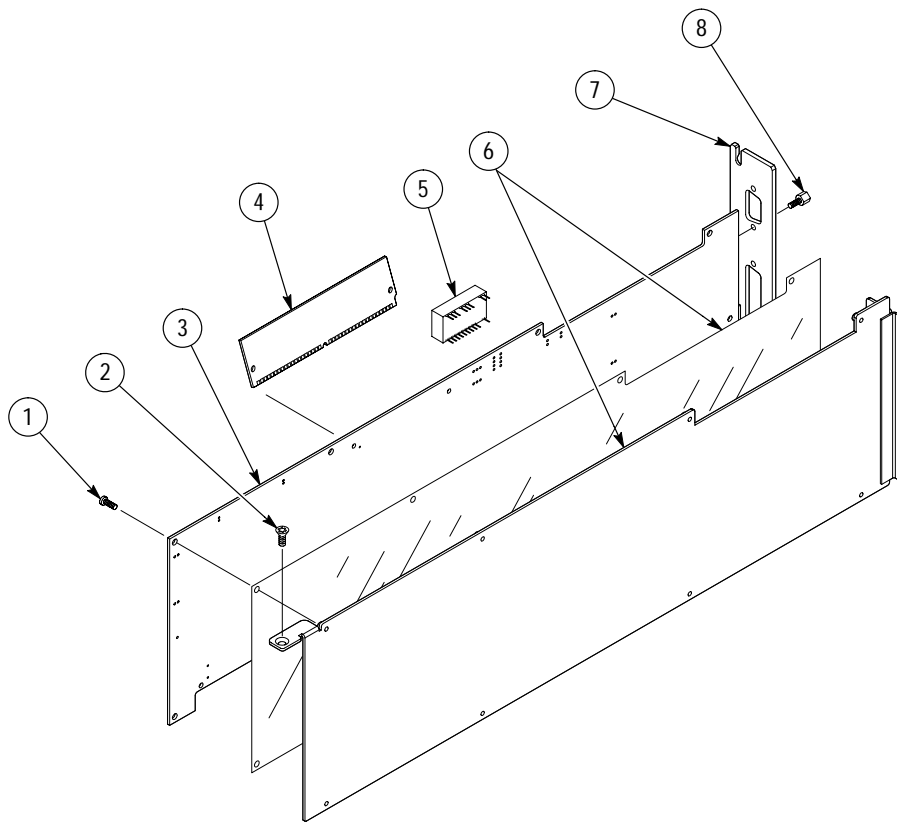

Figure 10-5: CPU assembly

Fig. & Index Number	Tektronix Part Number	Serial No. Effective	Serial No. Discont'd	Qty	Name & Description	Mfr. Code	Mfr. Part Number
6-	672-1472-00			1	MODULE ASSY:CLOCK, COMPLETE MODULE	80009	672-1472-00
-1	211-0408-00			8	SCR,ASSEM WSHR:4-40 X 0.250,PNH,STL,ZINC,T-10 TORX	0KB01	211-0408-00
-2	211-0012-00			2	SCREW,MACHINE:4-40 X 0.375,PNH,STL CD PL,POZ	93907	ORDER BY DESCR
-3	200-4141-00			1	COVER, TOP:POLYSTRNE,SPG422	7X318	200-4141-00
-4	119-4699-00			1	OVEN ASSEMBLY:TG2000	80009	119-4699-00
-5	348-1370-00			1	GASKET:0.062,POLYURETHANE,SPG422	2K262	348-1370-00
-6	432-0174-00			1	COVER,BOTTOM:POLYSTYRNE	7X318	432-0174-00
-7	671-2874-00			1	CIRCUIT BD ASSY:CLOCK	80009	671-2874-00
-8	337-3941-01			1	SHIELD,ELEC:ALUMINUM W/PLASTIC SHIELD	80009	337-3941-00
-9	333-4172-00			1	PANEL,REAR:REAR PANEL,CLOCK,ALUM,5.200 X 1.240	80009	333-4172-00
-10	211-0725-00			4	SCREW,MACHINE:6-32 X 0.375,FLH TORX	01536	ORDER BY DESCR

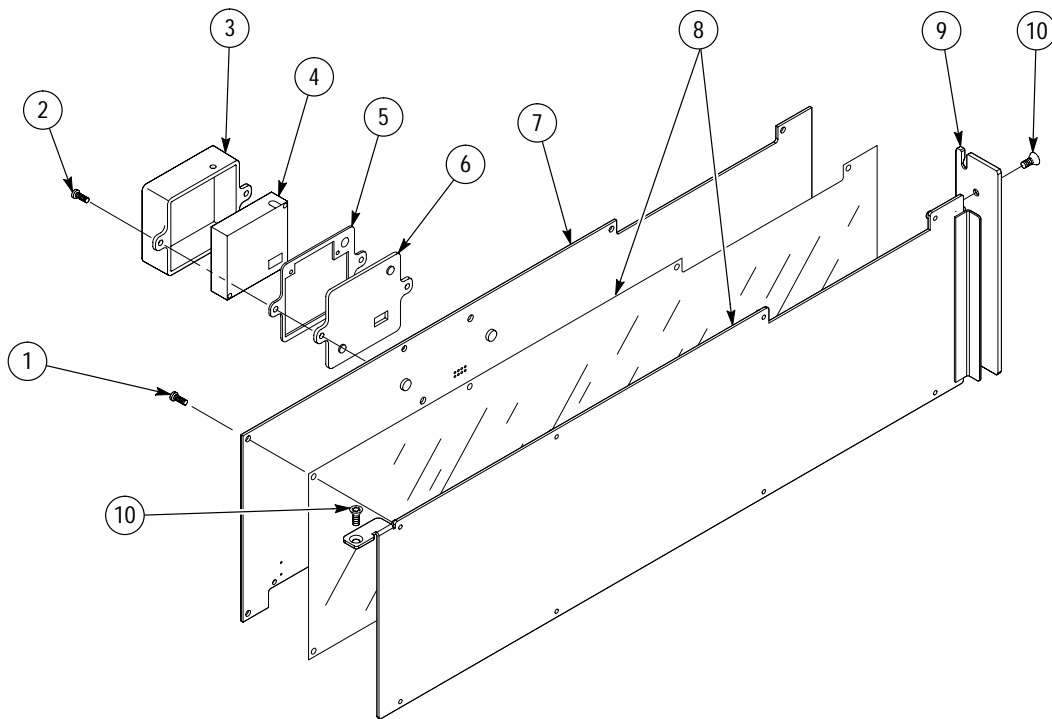

Figure 10-6: Clock assembly

Fig. & Index Number	Tektronix Part Number	Serial No. Effective	Serial No. Discont'd	Qty	Name & Description	Mfr. Code	Mfr. Part Number
7-	STANDARD ACCESSORIES						
	003-1604-00			1	TOOLS,SMALL:TORX INSERT BIT,1/4 HEX SHK,T-10	80009	003-1604-00
	159-0005-00			1	FUSE,CARTRIDGE:3A,250V (230V OPERATION ONLY)		
	159-0342-00			1	FUSE,CARTRIDGE:6A,250V (115V OPERATION ONLY)		
	333-4113-00			1	PANEL:REAR		
	351-0636-00	B010100	B010187	1	TRK,SL OUT SECT:STATIONARY &INTERMEDIATE	06666	351-0636-00
	351-0751-01	B010188		1	TRK,SL OUT SECT:STATIONARY &INTERMEDIATE	06666	351-0751-01
	070-9108-00			1	MANUAL,TECH:USERS,TG2000	80009	070-9108-00
	070-9267-00			1	MANUAL,TECH:USERS,SDP2000 W/ SDP2000 SOFTWARE	80009	070-9267-00
-1	161-0216-00			1	CABLE ASSY,PWR:3,18 AWG,2.5M L,BLACK (STANDARD ONLY)	80126	C7120-25M-BL
	OPTIONAL ACCESSORIES						
-2	161-0215-00			1	CABLE ASSY,PWR:3,0.75MU,2.5MM L,GREY (EUROPEAN OPTION A1 ONLY)	80126	0-5335-008-GY
-3	161-0066-10			1	CABLE ASSY,PWR:3,1.0 MM SQ,250V/10A,2.5 METER (UNITED KINGDOM OPTION A2 ONLY)	TK2541	ORDER BY DESCR
-4	161-0066-11			1	CABLE ASSY,PWR:3,1.0MM SQ,250V/10A,2.5 METER (AUSTRALIAN OPTION A3 ONLY)	80126	ORDER BY DESCR
-5	161-0066-12			1	CABLE ASSY,PWR:3,18 AWG,250V/10A,98 INCH (NORTH AMERICA OPTION A4 ONLY)	S3109	ORDER BY DESCR
-6	161-0154-00			1	CABLE ASSY,PWR:3,1.0MM SQ,250V/10A,2.5 METER (SWISS OPTION A5 ONLY)	5F520	86515030
	070-9299-00			1	MANUAL,TECH:SERVICE,TG2000	80009	070-9299-00
	070-9286-00			1	CIRCUIT BD:SERVICE EXTENDER	80009	070-9286-00

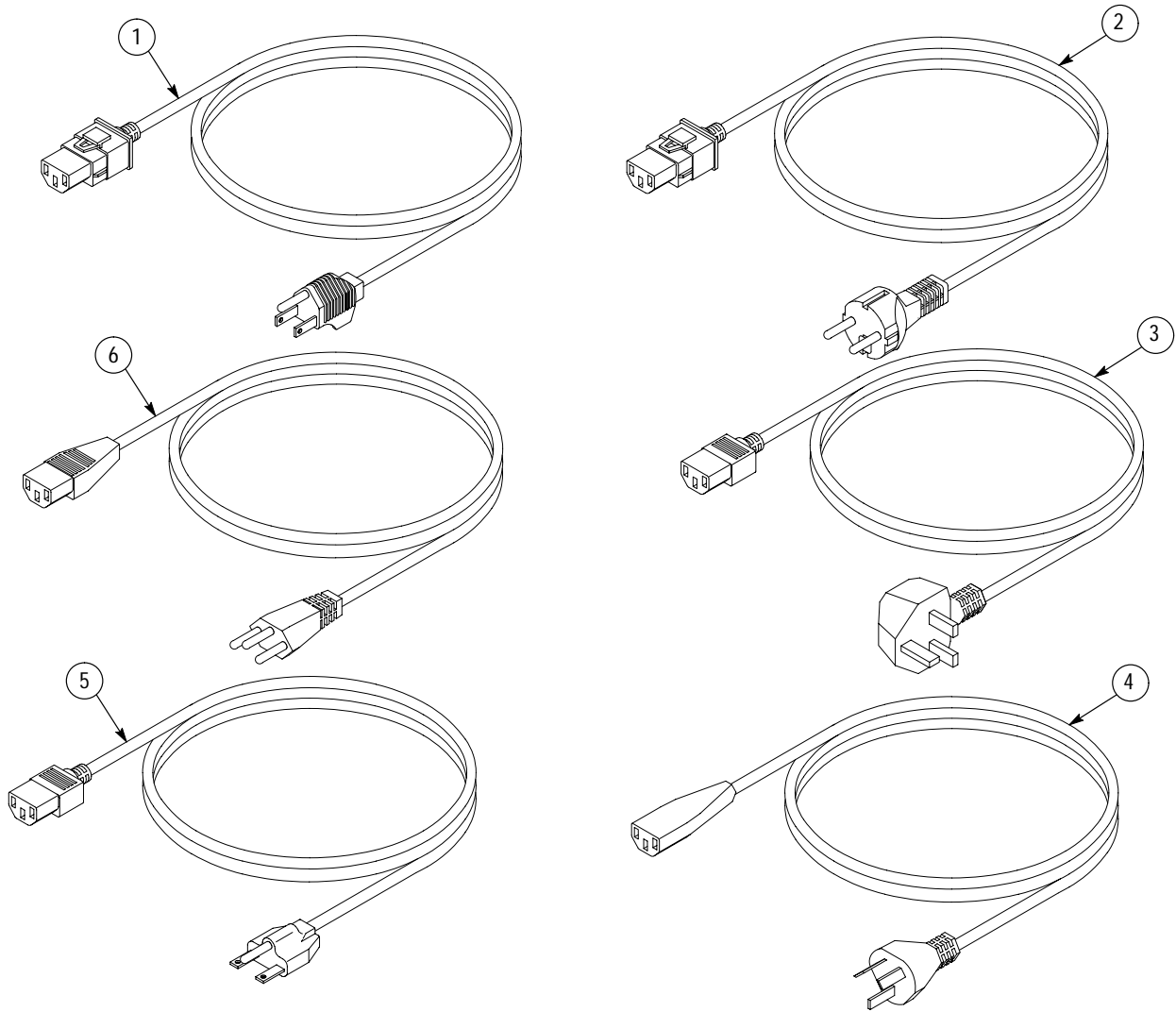

Figure 10-7: Accessories

Index

A

- AC power source, 1–3
- Accessories, 1–2, 10–16
- Adding signals from a disk, 2–16
- Adjust screen contrast, 2–10
- Adjustment procedures, 5–1
- After repair adjustments, 6–4
- AGL1 module connections, 9–4
- Arrow buttons, 2–8
- AVG1 module connections, 9–5
- AWVG1 module connections, 9–5

B

- Backplane board connections, 9–2
- Backup battery, description, 3–2
- Backup power, if lost, 2–21
- Batteries
 - charging, 2–21
 - replacing, 6–36
- BG1 module connections, 9–6
- Block diagram, 3–1, 3–4

C

- Calibration, 2–18, 5–2
- Certifications and compliances, 1–6
- Characteristics tables, 1–3
- Charging the batteries, 2–21
- Cleaning, 6–3
- Clearance for cooling, 1–4, 2–1
- Clock
 - frequency check, 4–7
 - signals, 3–3
 - specifications, 1–5
- Clock board, connections, 9–4
- Connectors, rear-panel, 2–19
- Cooling clearance, 1–4, 2–1
- CPU
 - confidence test codes, 6–40
 - configuration switch, 2–2, 2–3
 - connections, 9–3
 - function (system control), 3–1
 - module check, 4–3
- Creating new signals, 1–1

D

- Delay, 3–5
- Deleting signals, 2–18
- Diagrams, interconnect, 9–1
- Dimensions, 1–3
- Disk drive
 - check operation, 4–3
 - description, 3–2
 - replacing, 6–18
 - using, 2–13
- Display features, 2–10
 - hourglass, 2–11
 - icons, 2–10
 - list box, 2–10
 - page, 2–11
 - quit/save, 2–11
 - reset, 2–11
 - slot #, 2–10
 - status bar, 2–10
 - window title, 2–10
- Downloading signals, 2–15, 2–16
 - from remote, 1–2
- DVG1 module connections, 9–7

E

- Electrical installation, 2–1
- Electrostatic damage, 6–2
- Environmental characteristics, 1–3
- External reference genlock, 3–4

F

- Fans
 - operation check, 4–3
 - replacing, 6–32
- Fault symptom table, 6–40
- File types, supported, 2–13
- Firmware version, displayed in Utilities window, 2–7
- Frame reset signals, 3–3
- Front Panel Enable button, 2–9
- Front-panel
 - controls locked, 2–9
 - illustration, 2–7
 - interface check, 4–5

Front-panel board connections, 9–3
Fuse, 2–2
Fuse holder, replacing, 6–26
Fuse part numbers, 10–16

G

GP1 module connections, 9–6
GPIB interface, 2–10, 2–20

H

Help window, 2–7
Hourglass, 2–11

I

Icons, 2–10
Installation, 2–1
Interconnect diagrams, 9–1

K

Keypad, 2–8
Knob, 2–8

L

LCD contrast check, 4–6
LCD display screen, 2–10
Line filter, connections, 9–3
Line voltage setting, 2–2
List box, 2–10
Loading signals, 2–15, 2–16
Locked LED indicator, 2–7

M

Maintenance, 6–1
Memory, 3–2
Module
 exchange, 10–1
 hierarchy, 2–12
 memory, 2–12, 3–2
 parameters, 2–12
 repair, 10–1
 timing delay, 3–4
Modules, interconnect diagrams, 9–1

N

Navigation controls, 2–8

O

Operating information, 2–6
Option S1, 1–1
Optional accessories, 1–2, 10–16
Options, 7–1
Oscillator, adjustment, 5–5

P

Page icon, 2–11
Parallel interface, 2–9, 2–20
Parts list, 10–4
Parts ordering information, 10–1
Performance verification, 4–1
 verification interval, 4–1
Physical dimensions, 1–3
Power cords, 7–1
Power source, 1–3
Power supply, 3–2
 adjustment, 5–3
 voltages, 5–4, 6–42
Power supply board, connections, 9–3
Power switch
 front panel, 2–10
 rear panel, 2–2
Power-on procedure, 2–21
Presets, 2–13

Q

Quit/Save, 2–11

R

Rackmount
 installation, 2–3, 2–4
 removal, 2–5
Rear-panel connectors, 2–19
Remote button, 2–9
Remote control, description, 3–2
Remote interface
 GPIB, 2–10, 2–20
 parallel, 2–9, 2–20
 serial, 2–9, 2–20

Remote port, check operation, 4–6
 Removal and replacement procedures, 6–9
 Repackaging, 6–4
 Replaceable Parts List, 10–4
 Replacing

- batteries, 6–36
- disk drive, 6–18
- fans, 6–32
- fuse holder, 6–26

 Replacing signals from disk, 2–15
 Reset, 2–11
 RS-232 interface, 2–20

S

Safety certifications, 1–6
 Saving signals to disk, 2–13
 Screen contrast, 2–10
 Select button, 2–8
 Selecting test signals, 2–12
 Self calibration, 2–18, 5–2
 Sequences, 2–13
 Serial interface, 2–9, 2–20
 Shared module memory, 2–12
 Signal memory, 3–2
 Signal parameters, 2–12
 Signal sets, 2–13
 Signals

- adding, 2–16
- backing up before removing a module, 2–12
- creating new signals, 1–1
- deleting, 2–18
- replacing, 2–15
- saving to disk, 2–13

 Slot number, 2–10

Specifications, 1–3
 Standard accessories, 1–2, 10–16
 Status bar, 2–10
 Status of instrument, 2–7
 Supported file types, 2–13
 Switch setting, CPU configuration, 2–3
 System clock specifications, 1–5
 System control, 3–1
 System delay, 3–5
 System Function buttons, 2–6
 System reference delay, 3–6

T

Temperature, operating/nonoperating, 1–3
 Test signal hierarchy, 2–12
 Test signals, 2–12
 Theory of operation, 3–1
 Timing delay, 3–6
 Timing references, 3–4
 Touch screen, 2–10
 Troubleshooting, 6–37

- flowcharts, 6–41

U

Using the disk drive, 2–13
 Utilities button, 2–7

W

Weight of product, 1–3
 Window title, 2–10

